

**L.J. Smith**  
**Stair Systems**

# BALUSTRADE INSTALLATION GUIDE

*For use with the "LJ" Line of stair parts*

**This document is a  
step-by-step installation  
guide for L.J. Smith Stair  
Systems.**

- This document can be printed in its entirety, or you can click through the individual steps online.
- To begin online viewing, click on the hand at the bottom of this page.
- Continue navigating through the guide by clicking on the "GO TO" boxes to go to the next step.

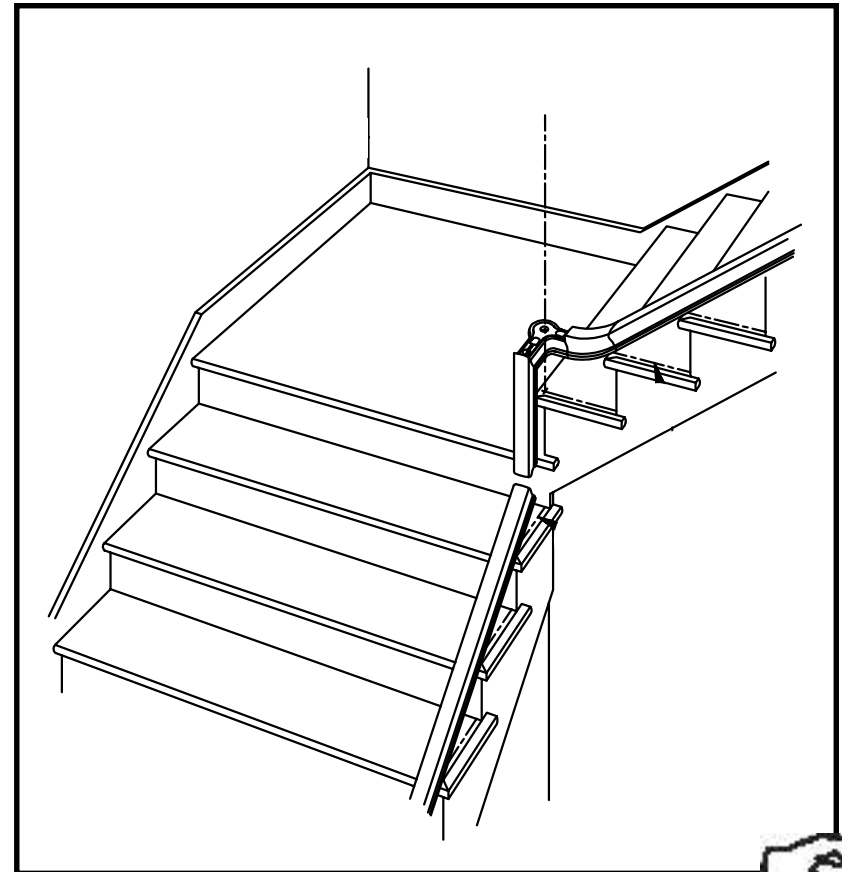

## 1

## INTRODUCTION

This **BALUSTRADE INSTALLATION GUIDE** has been revised to be used with the LJ Line of stair parts. Beginning with this introduction, Step 1, you will be guided through the steps required for your particular stairway by a note at the bottom of each step indicating which step to go to next. This approach has two benefits: first, you will be referred only to the steps you need, and secondly, the sequence is designed with efficiency in mind and will help ensure that mistakes are not made by doing something out of sequence.

An appendix for troubleshooting and unusual installations, Step 107, and a quick reference index, Step 108, round out the guide.

**Important: Before beginning your installation, take time to thoroughly read all of the steps required for your stair.**

[GO TO 2](#)

## 2

## GENERAL NOTES

**IMPORTANT: Cut and fit all parts before permanently installing any of them. This will help reduce the chance of error.**

- 2A The LJ Line of Conect-A-Kit fittings are designed to decrease installation time. The time spent assembling the various components is outweighed by the time saved by avoiding the use of rail bolts.
- 2B The LJ Line of balusters and newels is designed to accommodate virtually any building code requirement.
- 2C In order to provide a solid and durable installation, and to avoid squeaks, avoid the use of nails wherever possible. Use woodscrews, lag bolts, rail bolts and assembly glue on all joints.

- 2D Newels are the primary support of any balustrade system and are recommended at the beginning, end, and at all changes of direction on a stairway.
- 2E Balcony newels should be located no more than ten feet (10') apart.
- 2F Consult your local building codes prior to installation.
- 2G All stair parts are for interior use and installation only.

[GO TO 3](#)

## 3

## BUILDING CODES

GENERAL - It will be necessary to determine the following code requirements prior to beginning installation.

## RAKE HANDRAIL HEIGHT

The minimum vertical distance from the tread nosing to the top of the handrail.

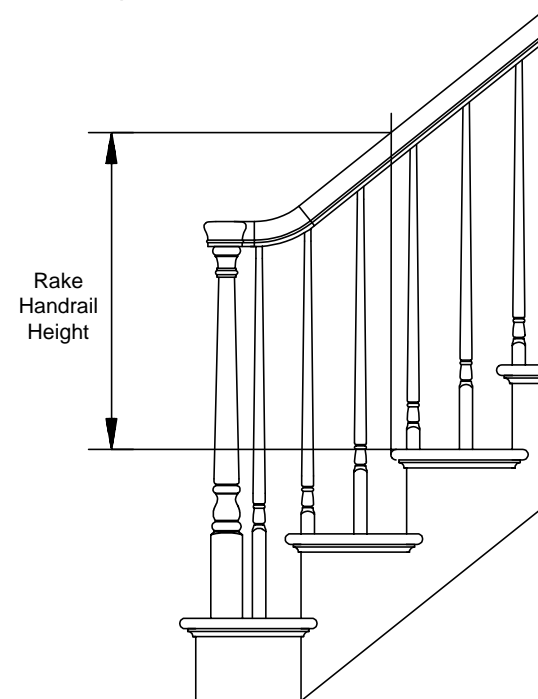

### BALCONY GUARDRAIL HEIGHT

The minimum vertical distance from the finished floor to the top of the level railing.

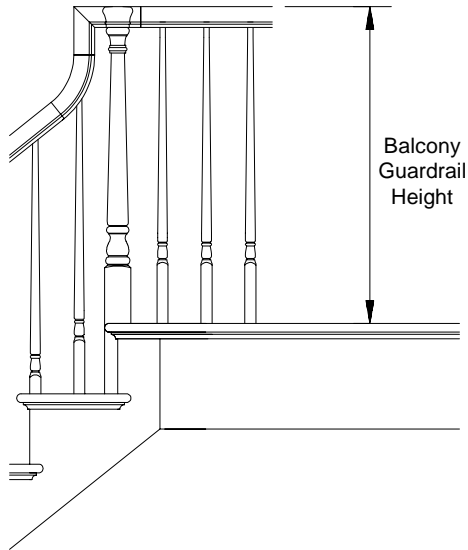

### BALUSTER SPACING

The maximum spacing permitted between balusters. This will determine the number of balusters required for each tread.

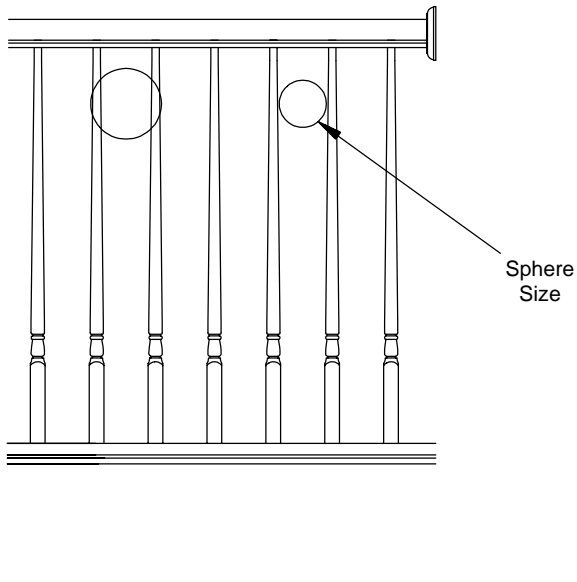

### HANDRAIL CLEARANCE

The minimum clearance required between the handrail and any other object; such as a wall or landing tread nosing.

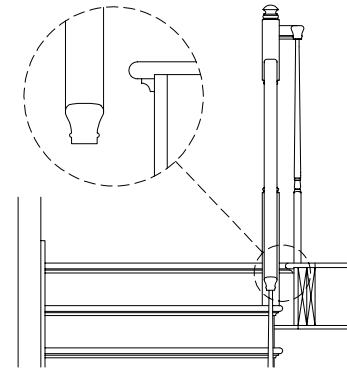

**GO TO 4**

**4**

**IS STAIR OVER THE POST OR  
POST TO POST?**

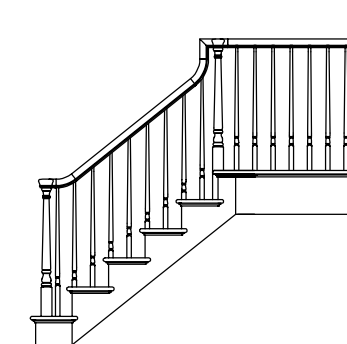

**OVER THE POST  
GO TO 5**

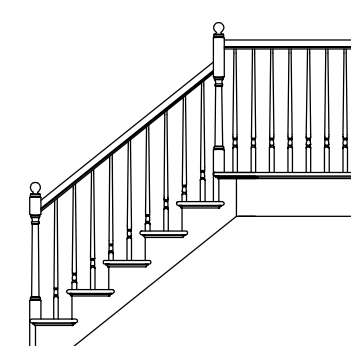

**POST TO POST  
GO TO 6**

5

**OVER THE POST**

**DETERMINE THE TYPE OF INSTALLATION - OVER THE POST**

The illustrations below will help determine the type of installation required.

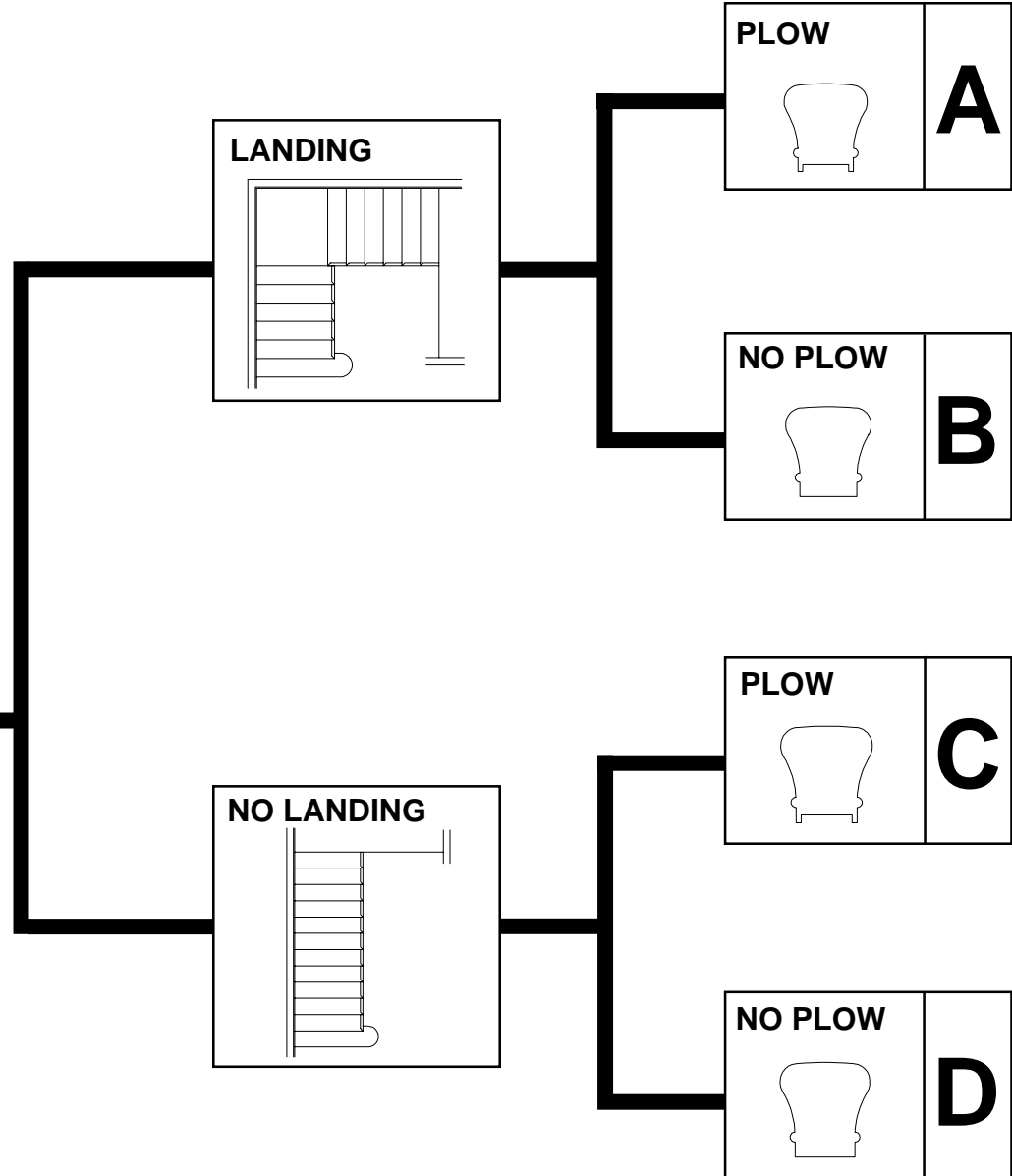
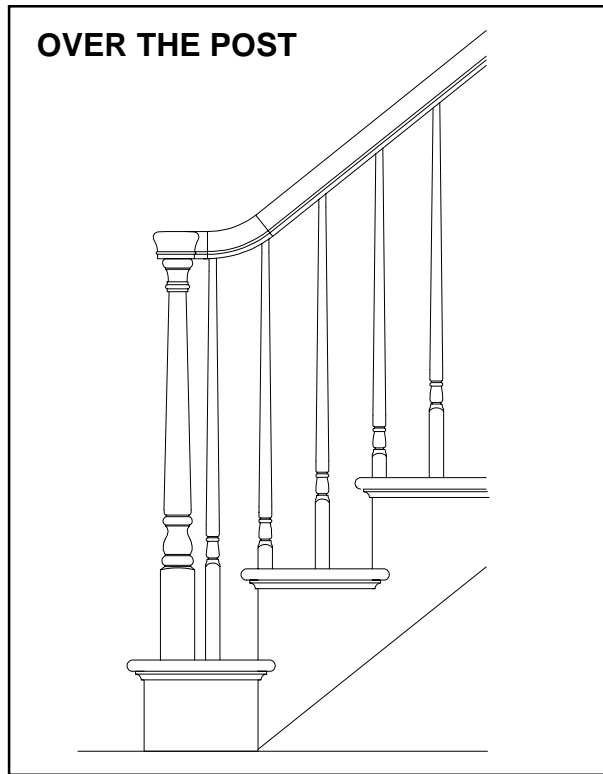

For example, a type **C** stair is over the post, does not have an intermediate landing and uses plowed handrail.

Remember the letter for your stair, as the "GO TO . . ." boxes at the end of each step may tell one letter to go on to the next step and tell another letter to skip one or more steps.

6

**POST TO POST**

**DETERMINE THE TYPE OF INSTALLATION - POST TO POST**

The illustrations below will help determine the type of installation required.

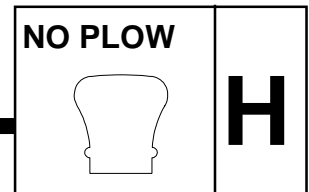
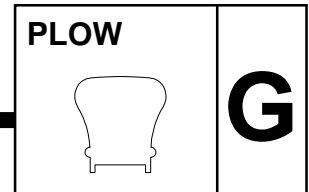
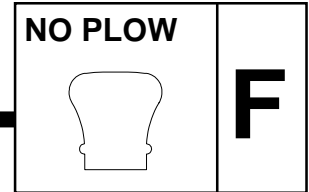
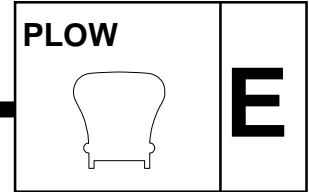
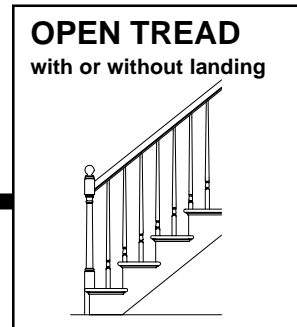
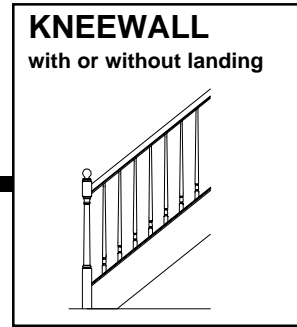
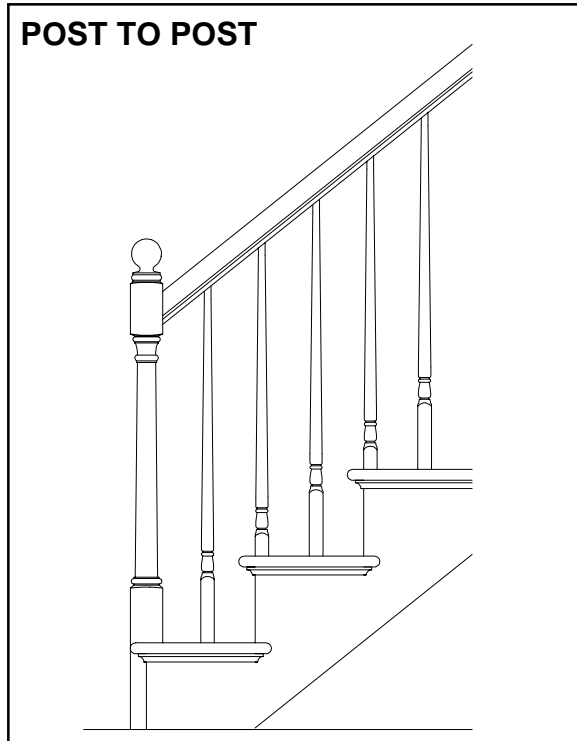

For example, a type **F** stair is post to post, has a kneewall and uses unplowed handrail.

Remember the letter for your stair, as the "GO TO . . ." boxes at the end of each step may tell one letter to go on to the next step and tell another letter to skip one or more steps.

**E,F,G,H - GO TO 7**

7

## MARK THE BALUSTRADE CENTERLINE AND NEWEL CENTERPOINTS

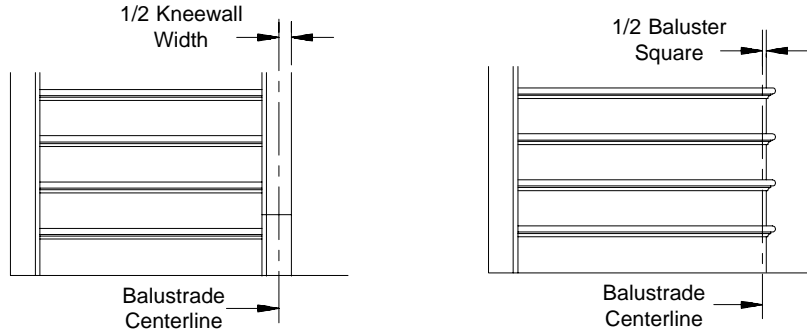

FRONT VIEW

The balustrade centerline and newel centerpoints can easily be laid out using the L.J. Smith C-88 Centerline Tool. On a **kneewall** stair, the balustrade should be centered on the kneewall. On an **open-tread** stair, the centerline should be 1/2 of the baluster square in from the face of the stringer; i.e.: 5/8" for a 1-1/4" baluster.

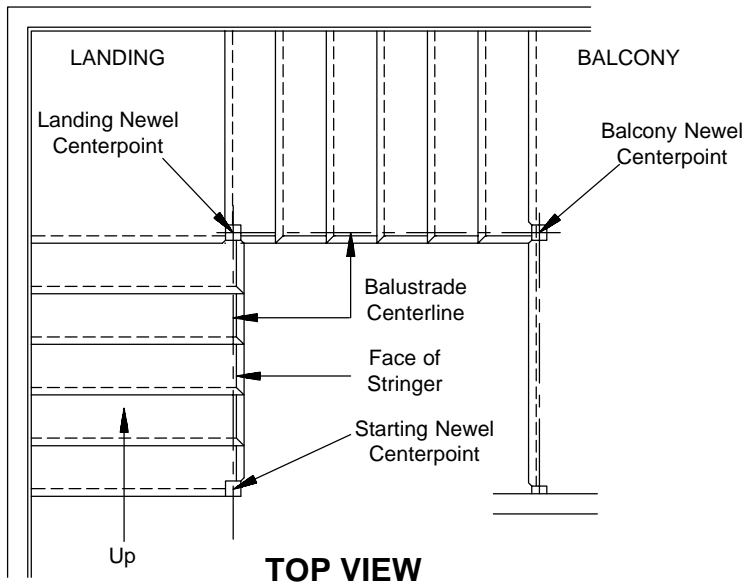

TOP VIEW

The newel centerpoints lie at the intersections of the balustrade centerlines. Note that the above method typically requires the notching of newels as described in step **107-A**.

An alternate method of locating the balustrade centerline which does not require newel notching is described below.

### ALTERNATE VIEW

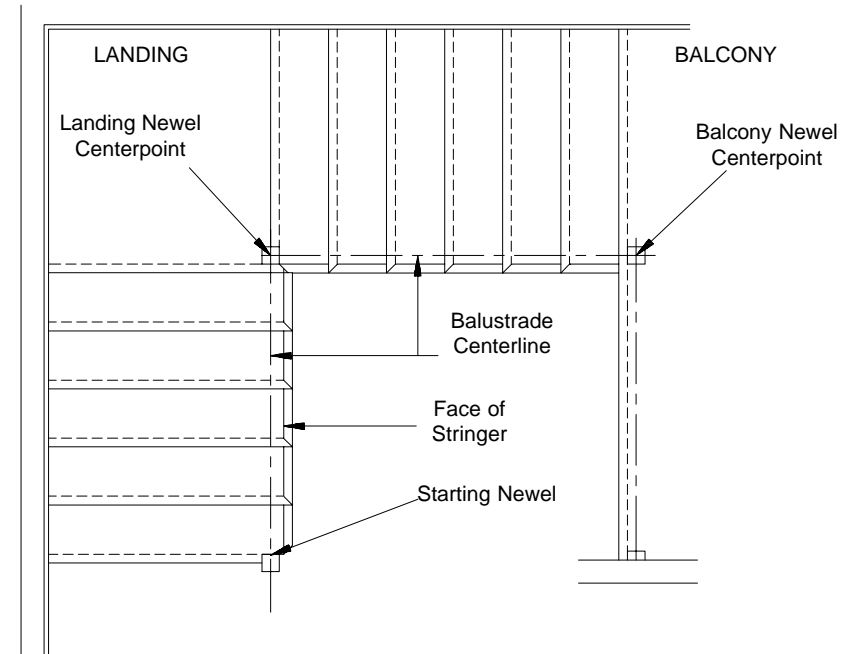

One method which does not require the notching of newels is to mount the starting newel and intermediate landing newel directly against the riser. The balcony newel may be mounted flush to the floor with no overhang. Note that these methods may reduce the stair width and could pose problems in terminating the balcony rail at a wall as well as effect the location of the starting fitting template.

A, B, C, D, G, H - GO TO 8

E, F - GO TO 9

**8 MARK THE BALUSTER CENTERPOINTS**

From the baluster spacing required by code see step 3, determine the number of balusters required per tread. The first baluster of each tread should be 1/2 baluster square back from the face of the riser. Divide the run by the required number of balusters per tread to find the center-to-center distance for the other balusters. For example, if the run is 10" and the maximum spacing required by code is 4"; 10 divided by 4 equals 2-1/2 spaces required per tread. Round this up to 3 spaces. Thus, 3 balusters per tread are required. 10" run divided by 3 balusters equals 3.333" (3-11/32") center-to-center.

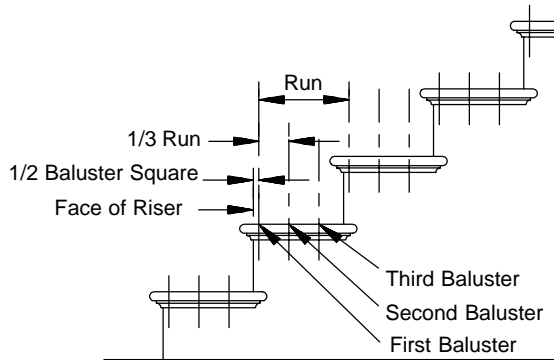
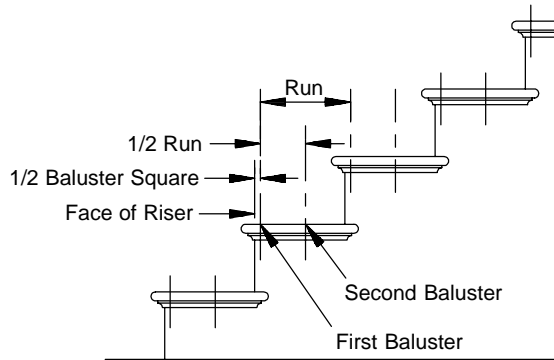

**A, B, C, D - ARE YOU USING AN OPENING CAP?  
YES - GO TO 11 / NO - GO TO 10**

---

**G, H - GO TO 48**

**9 MARK THE BALUSTER CENTERPOINTS**

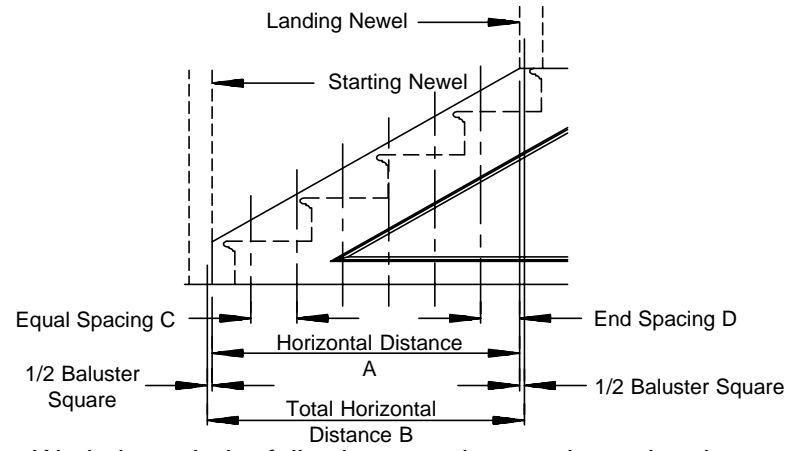

Work through the following equations to determine the proper center-to-center baluster spacing. Use the end distance, obtained in Equation number 4, and the equal distance, obtained in Equation number 3. Mark these points on the floor and double check that they add up to the total horizontal distance. Use a pumb-bob to plumb up from these points to mark the kneewall. Keep the spacing on different flights and on the balcony as consistent as possible.

EQUAL SPACING CENTER-TO-CENTER (C):

Equation 1  +  =   
 (A) Horizontal Distance      Size of one Baluster Square      (B) Total Horizontal Distance

Equation 2  ÷  =   
 (B) Total Horizontal Distance      Spacing Required by Code      Number of Spaces (Round up)

Equation 3  ÷  =   
 (B) Total Horizontal Distance      Number of Spaces      (C) Equal Spacing Center-to-Center

END SPACING (D) From face of Newel to Center of First Baluster):  
 Equation 4  -  =   
 (C) Equal Spacing Center-to-Center      1/2 Baluster Square      (D) End Spacing

**GO TO 48**

10

TRACE THE STARTING FITTING TEMPLATE

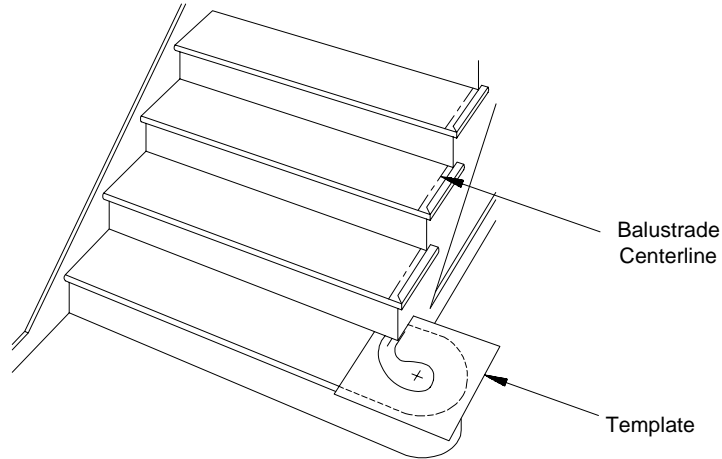

Using the template provided with your starting fitting; align the balustrade centerline and mark the newel and baluster centerpoints on the starting tread.

**ARE YOU USING A CLIMBING VOLUTE?**  
**YES - GO TO 107-P / NO - GO TO 11**

11

MARK THE STARTING EASING

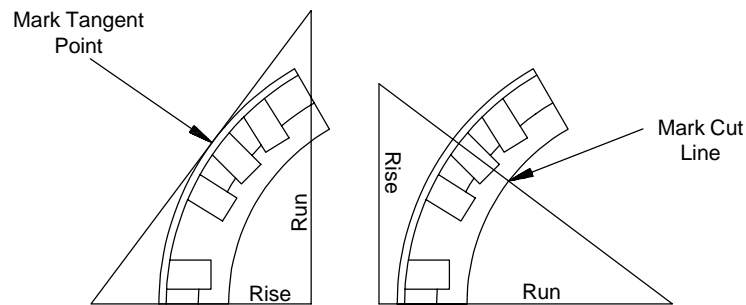

**Always trim the end of the easing which has three pockets.** Mark the tangent point on the easing with the "rise" leg of the pitchblock lying flat. Mark the cut line on the easing with the "run" leg of the pitchblock lying flat. **Note:** See Step 107-E for instructions on how to make a pitchblock.

**GO TO 12**

12

TRIM THE STARTING EASING

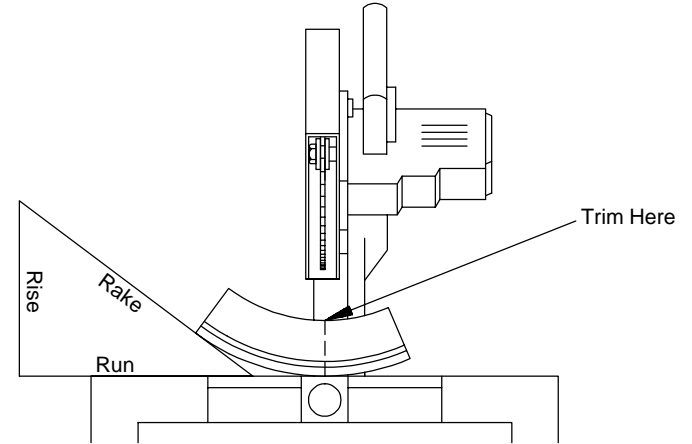

Trim the starting easing along the cut line using a miter saw. A pitchblock may be used for support.

**ARE YOU USING AN OPENING CAP?**  
**YES - GO TO 14 / NO - GO TO 13**

13

ASSEMBLE THE STARTING FITTING

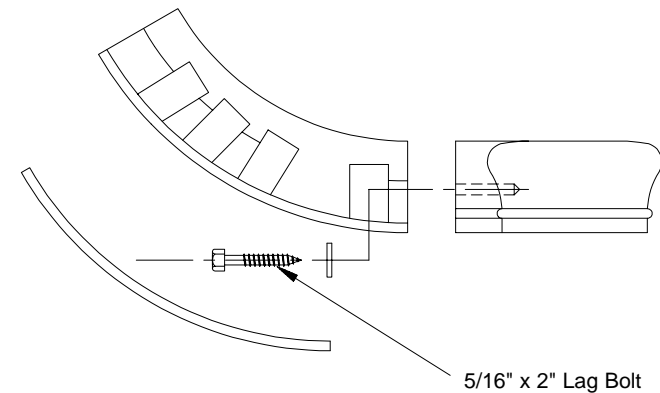

Remove the filler from the easing. Use a 5/16" x 2" lag bolt and washer to assemble the **single pocket end** of the easing to the volute or turnout.

**GO TO 16**

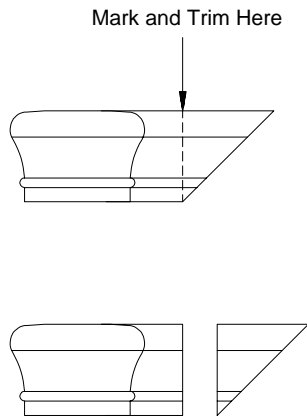
**14**
**SQUARE CUT THE OPENING CAP**

The mitered end of the opening cap must be square cut in order to be assembled to the easing. Mark the opening cap at the bottom edge of the miter. Square cut the opening cap at the mark using a miter saw.

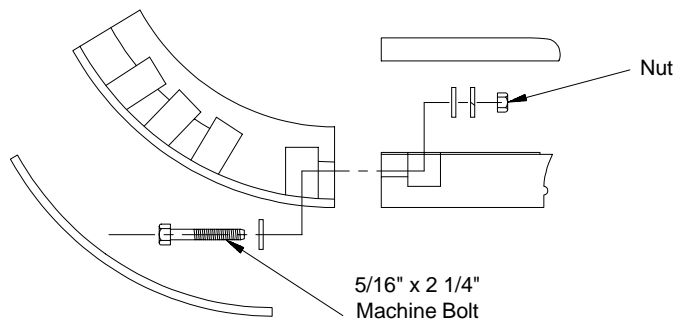
**GO TO 15**
**15**
**ASSEMBLE THE STARTING FITTING**

Carefully remove the top lid of the opening cap using a putty knife or chisel. Use a 5/16" x 2 1/4" machine bolt and nut to assemble the **single pocket end** of the easing to the opening cap. Use a 3/8" SAE washer on the bolt head end, and a 3/8" SAE washer with a 5/16" lock washer on the nut end.

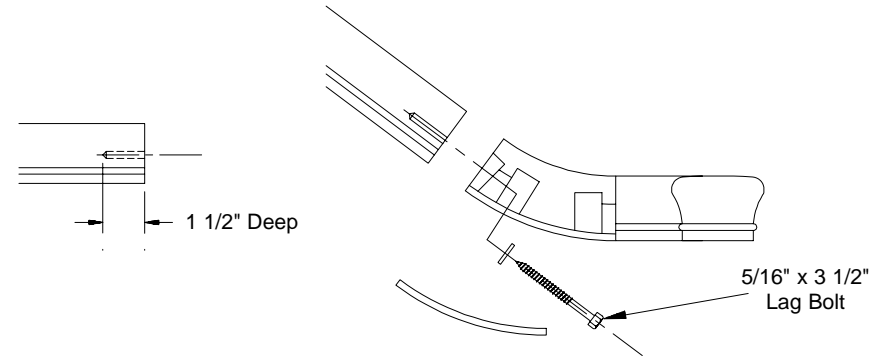
**GO TO 16**
**16**
**ASSEMBLE THE STARTING FITTING TO THE HANDRAIL**

Use the Rail Marking Template to mark the handrail. Drill a 1/4" x 1-1/2" deep pilot hole in the handrail. Assemble the starting fitting to the handrail with a 5/16" x 3-1/2" lag bolt and washer.

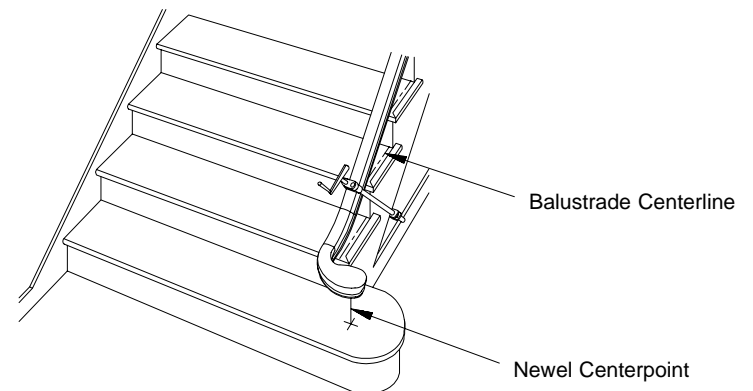
**GO TO 17**
**17**
**CLAMP THE STARTING FITTING AND HANDRAIL TO THE STAIR**

Clamp the assembly to the stair tread nosings using bar clamps. Locate the handrail over the balustrade centerline and the starting fitting directly over the starting newel centerpoint.

**GO TO 18**

18

**MEASURE THE GAP UNDER THE STARTING FITTING**

Measure the vertical distance from the tread to the underside of the starting fitting. Write this dimension down for future use.

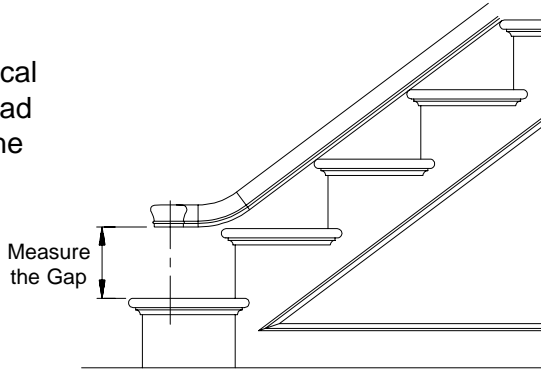

**MEASUREMENT**

**GO TO 19**

19

**MEASURE THE RAKE HANDRAIL THICKNESS**

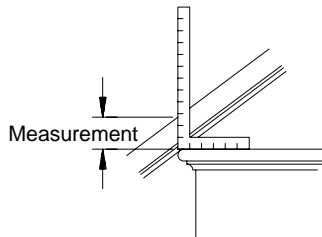

Measure the height of the handrail above the tread nosing while clamped to the treads or kneewall. Be sure the framing square is sitting on a tread and is lined up with the nosing. Write this measurement down.

**MEASUREMENT**

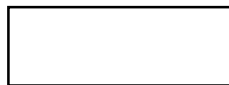

**A,B - GO TO 20 / C,D - GO TO 33**

20

**SQUARE CUT THE INTERMEDIATE LANDING FITTING**

The mitered end of the intermediate landing fitting must be square cut in order to be assembled to the easing. Mark the intermediate landing fitting at the bottom edge of the miter. Square cut the fitting using a miter saw.

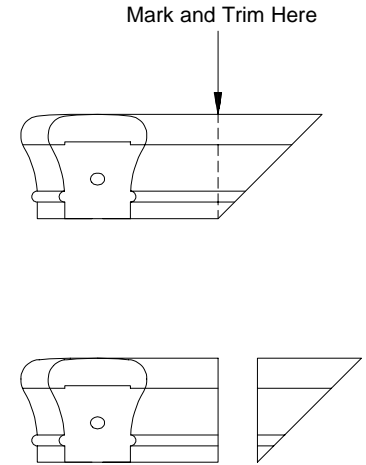

**GO TO 21**

21

**MARK THE EASING AT THE LOWER END OF THE SECOND FLIGHT**

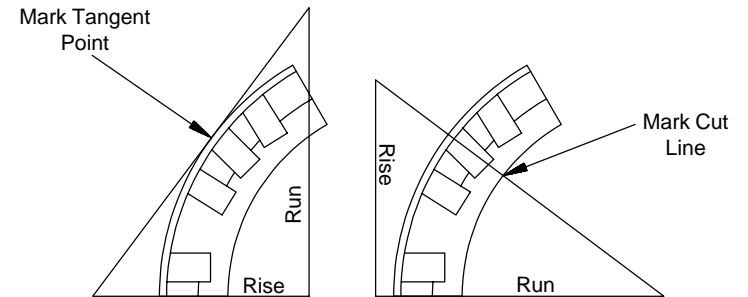

**Always trim the end of the easing which has three pockets.** Mark the tangent point on the easing with the "rise" leg of the pitchblock lying flat. Mark the cut line on the easing with the "run" leg of the pitchblock lying flat. **Note:** See Step 107-E for instructions on how to make a pitchblock.

**GO TO 22**

22

TRIM THE EASING

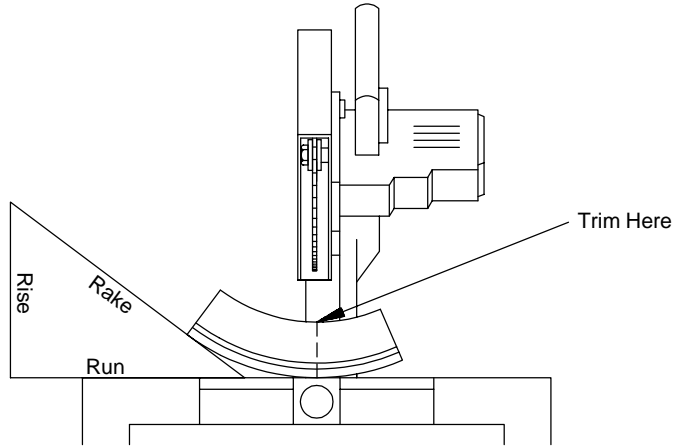

Trim the easing along the cut line using a miter saw. A pitchblock may be used for support.

GO TO 23

23

ASSEMBLE THE EASING TO THE INTERMEDIATE LANDING FITTING

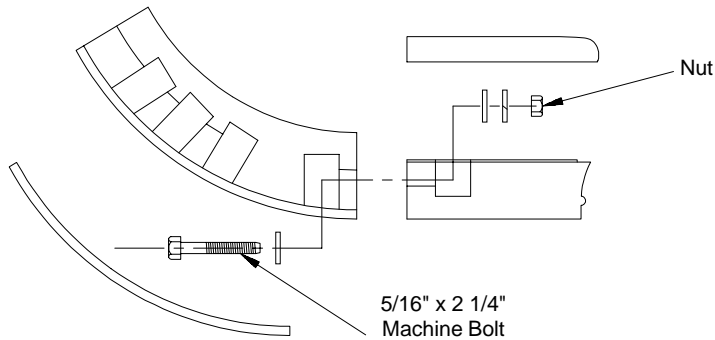

Use a 5/16" x 2 1/4" machine bolt and nut to assemble the **single pocket end** of the easing to the intermediate landing fitting. Use a 3/8" SAE washer on the bolt head end, and a 3/8" SAE washer with a 5/16" lock washer on the nut end.

GO TO 24

24

ASSEMBLE THE INTERMEDIATE LANDING FITTING TO THE SECOND FLIGHT HANDRAIL

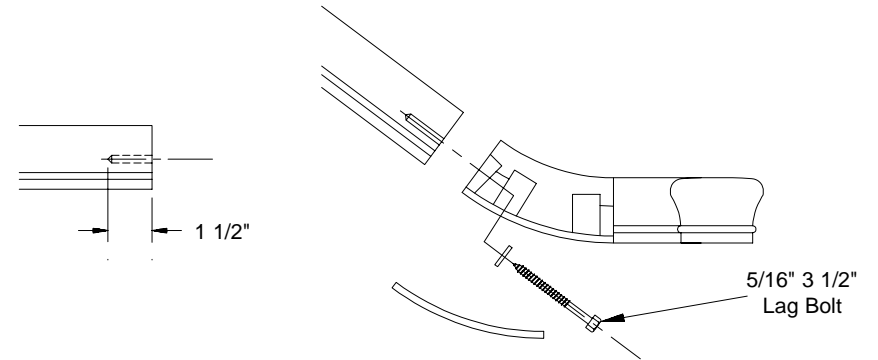

Use the Rail Marking Template to mark the handrail. Drill a 1/4" x 1-1/2" deep pilot hole in the handrail. Assemble the intermediate landing fitting to the handrail with a 5/16" x 3-1/2" lag bolt and washer.

GO TO 25

25

ASSEMBLE THE RAIL DROP TO THE INTERMEDIATE LANDING FITTING

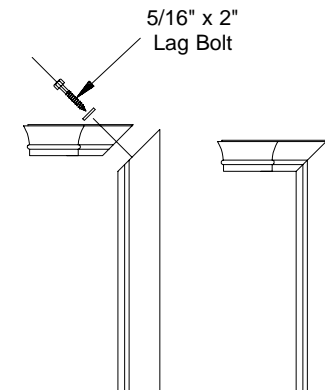

Assemble the rail drop to the intermediate landing fitting with a 5/16" x 2" lag bolt and washer.

GO TO 26

**26 CLAMP THE INTERMEDIATE LANDING FITTING AND HANDRAIL TO THE STAIR**

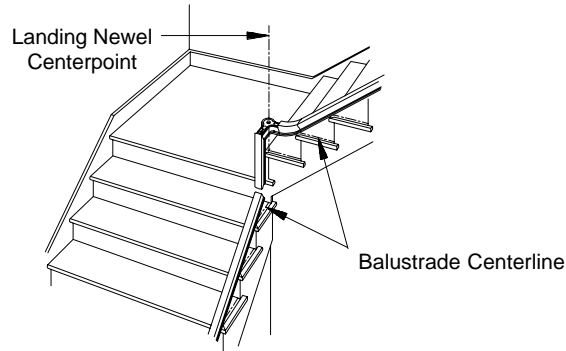

Clamp the assembly to the stair tread nosings using bar clamps. Locate the handrail over the balustrade centerline and the intermediate landing fitting directly over the landing newel centerpoint.

**GO TO 27**

**27 MEASURE THE GAP UNDER THE INTERMEDIATE LANDING FITTING**

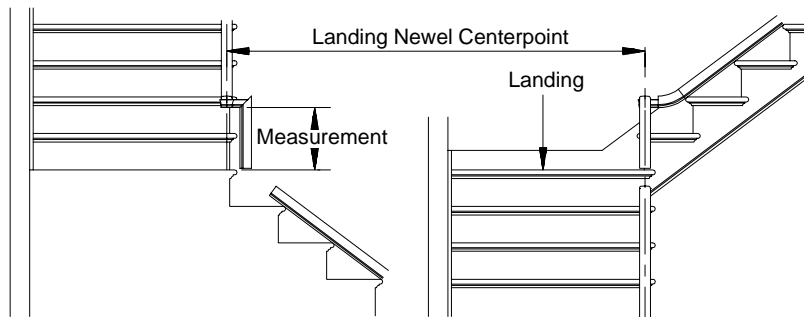

Measure the vertical distance from the level of the landing to the underside of the intermediate landing fitting. Write this dimension down for future use.

**MEASUREMENT**

**GO TO 28**

**28 MARK THE EASING AT THE TOP OF THE FIRST FLIGHT**

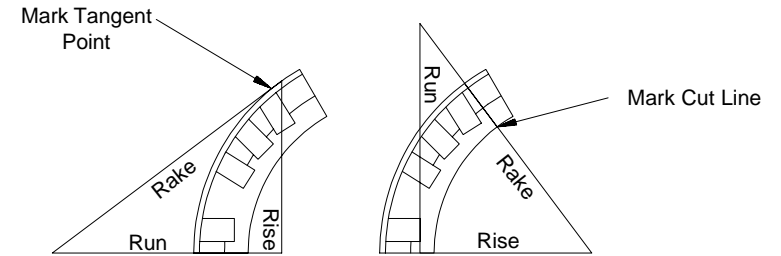

**Always trim the end of the easing which has three pockets.** Stand the easing up on a level surface. Mark the tangent point on the easing with the "run" leg of the pitchblock lying flat. Mark the cut line on the easing with the "rise" leg of the pitchblock lying flat. **Note:** See step 107-E for instructions on how to make a pitchblock.

**GO TO 29**

**29 TRIM THE EASING AT THE TOP OF THE FIRST FLIGHT**

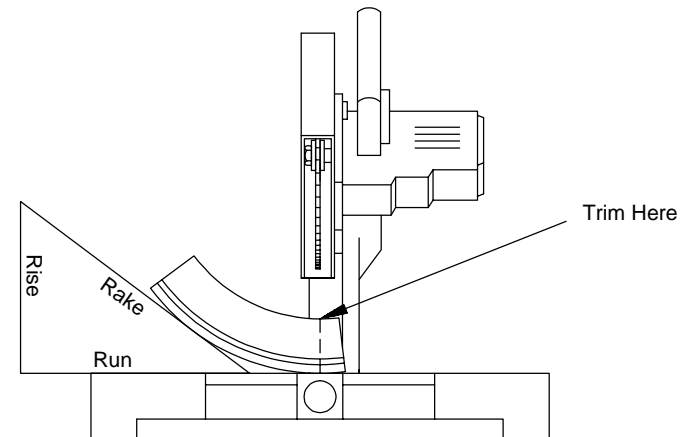

Trim the easing along the cut line using a miter saw. A pitchblock may be used for support, as shown.

**GO TO 30**

30

### APPLY A PLYWOOD SEAT TO THE RAIL DROP AND THE FIRST FLIGHT HANDRAIL

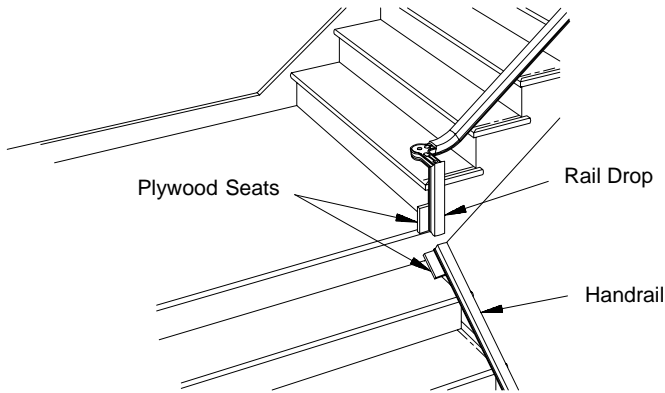

Tack-nail 4"-6" wide pieces of plywood to the underside of the rail drop and to the handrail. This will be used as a temporary seat for marking the rail drop and handrail for trimming.

**GO TO 31**

31

### MARK AND TRIM THE RAIL DROP AND THE FIRST FLIGHT HANDRAIL

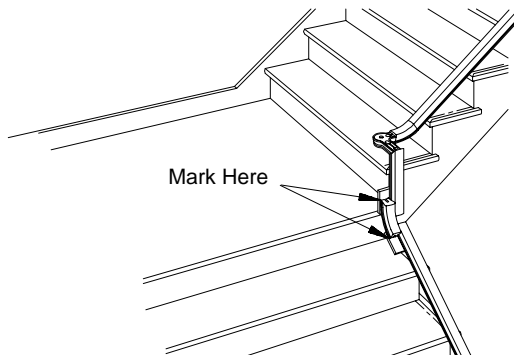

Place the trimmed easing on the plywood seats beside the rail drop and the handrail. Use a torpedo level or LJ-3037 Rail Fitting Level to level the upper end of the easing. Mark the rail drop and the handrail as shown. Trim the rail drop and the handrail at these marks using a miter saw.

**GO TO 32**

32

### ASSEMBLE THE EASING TO THE RAIL DROP AND THE FIRST FLIGHT HANDRAIL

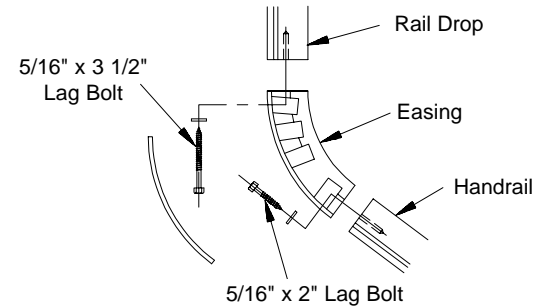

Use the Rail Marking Template to mark the rail drop and the handrail. Drill a 1/4" x 1-1/2" deep pilot hole in the rail drop and the handrail. Assemble the **single pocket end** of the easing to the handrail with a 5/16" x 2" lag bolt and washer. Assemble the **trimmed end** of the easing to the rail drop with a 5/16" x 3-1/2" lag bolt and washer.

**GO TO 33**

33

### SQUARE CUT THE BALCONY FITTING

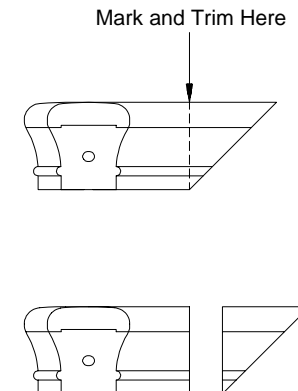

The mitered end of the balcony fitting must be square cut in order to be assembled to the balcony handrail. Mark the balcony fitting at the bottom edge of the miter. Square cut the balcony fitting at the mark using a miter saw.

**GO TO 34**

**34 ASSEMBLE THE RAIL DROP TO THE BALCONY FITTING**

Carefully remove the top lid of the balcony fitting using a putty knife or chisel.

Assemble the rail drop to the balcony fitting with a 5/16" x 2" lag bolt and washer.

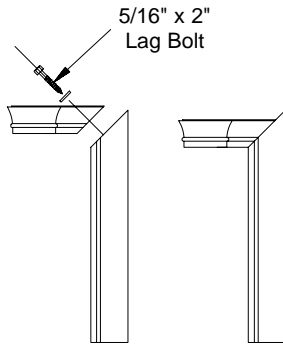

**GO TO 35**

**35 CALCULATE THE BALCONY FITTING SUPPORT BLOCK HEIGHT**

Make a temporary support block out of a 4 x 4 or other material. The support block height equals:

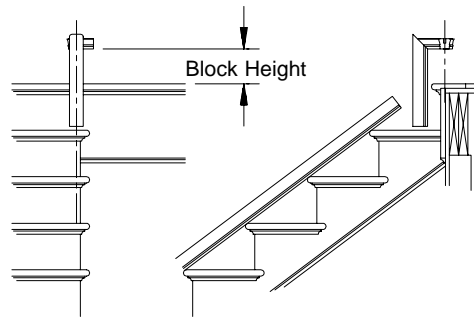

	MINUS		PLUS		MINUS		EQUALS	
Balcony Rail Height From Step 3	-	Rake Rail Height From Step 3	+	Rake Rail Thickness From Step 19	-	Level Rail Thickness	=	

**HEIGHT OF SUPPORT BLOCK**

**GO TO 36**

**36 MARK THE EASING AT THE TOP OF THE FLIGHT**

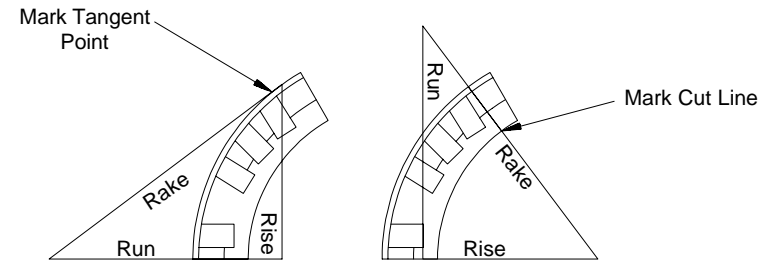

**Always trim the end of the easing which has three pockets.** Stand the easing up on a level surface. Mark the tangent point on the easing with the "run" leg of the pitchblock lying flat. Mark the cut line on the easing with the "rise" leg of the pitchblock lying flat. **Note:** See step 107-E for instructions on how to make a pitchblock.

**GO TO 37**

**37 TRIM THE EASING AT THE TOP OF THE FLIGHT**

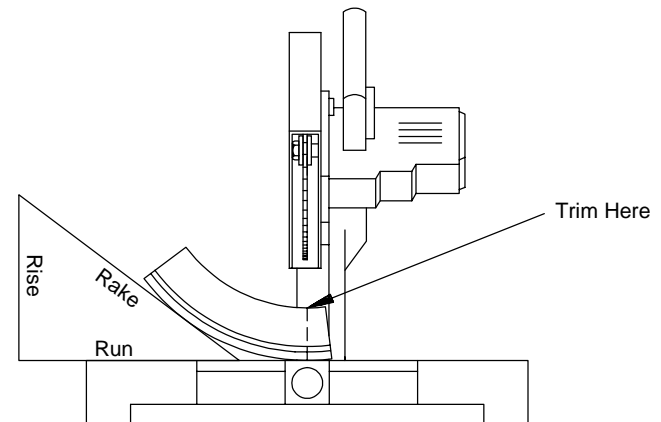

Trim the easing along the cut line using a miter saw. A pitchblock may be used for support, as shown.

**GO TO 38**

**38** APPLY A PLYWOOD SEAT TO THE RAIL DROP AND THE STAIR HANDRAIL

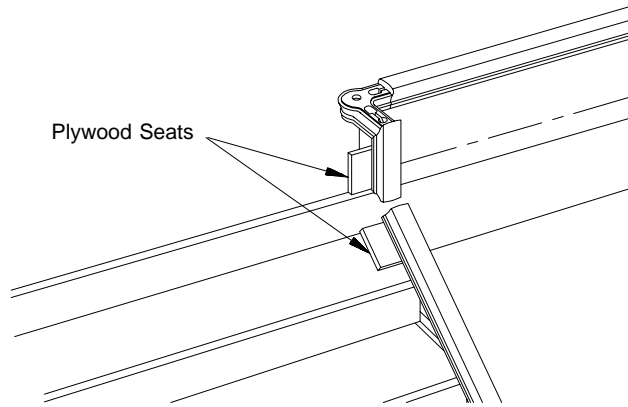

Tack-nail 4"-6" wide pieces of plywood to the underside of the rail drop and to the stair handrail. This will be used as a temporary seat for marking the rail drop and the stair handrail for trimming.

**GO TO 39**

**39** MARK AND TRIM THE RAIL DROP AND THE STAIR HANDRAIL

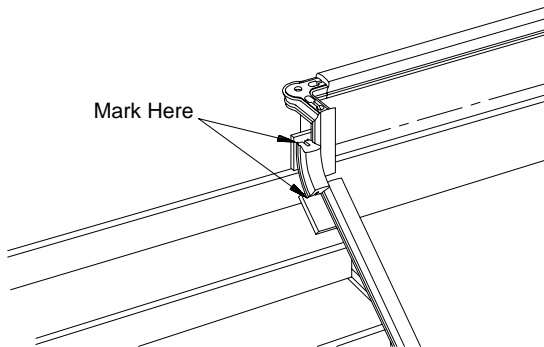

Place the trimmed easing on the plywood seats beside the rail drop and the stair handrail. Use a torpedo level or LJ-3037 Rail Fitting Level to level the upper end of the easing. Mark the rail drop and the stair handrail as shown. Trim the rail drop and the stair handrail at these marks using a miter saw.

**GO TO 40**

**40** ASSEMBLE THE EASING TO THE RAIL DROP AND THE STAIR HANDRAIL

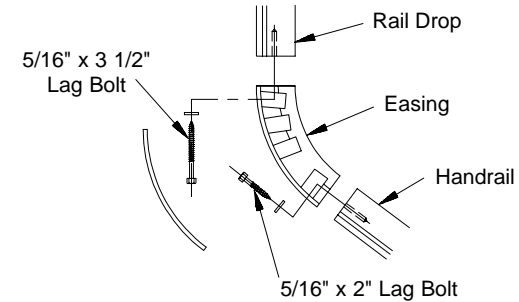

Use the Rail Marking Template to mark the rail drop and the stair handrail. Drill a 1/4" x 1-1/2" deep hole in the rail drop and the stair handrail. Assemble the **single pocket end** of the easing to the stair handrail with a 5/16" x 2" lag bolt and washer. Assemble the **trimmed end** of the easing to the rail drop with a 5/16" x 3-1/2" lag bolt and washer.

**GO TO 41**

**41** CALCULATE THE STARTING NEWEL HEIGHT

Rake handrail height is described in step 3. To calculate the starting newel height, refer to the measurements written down in steps 18 and 19. The starting newel height from the top of the starting tread equals:

	PLUS		MINUS		EQUALS
Rake Rail Height From Step 3	+	From Step 18	-	From Step 19	=

**Note:** This dimension does not include the pin at the top of the newel nor any part of the bottom block which extends below the level of the starting tread.

**GO TO 42**

**42 TRIM AND FASTEN THE STARTING NEWEL**

Trim the starting newel using the dimension obtained in step 41. Fasten the newel using the hardware and instructions provided. Drill a pilot hole in the tread at the starting newel centerpoint to receive the threaded insert. Drill a pilot hole in the newel for the hanger bolt.

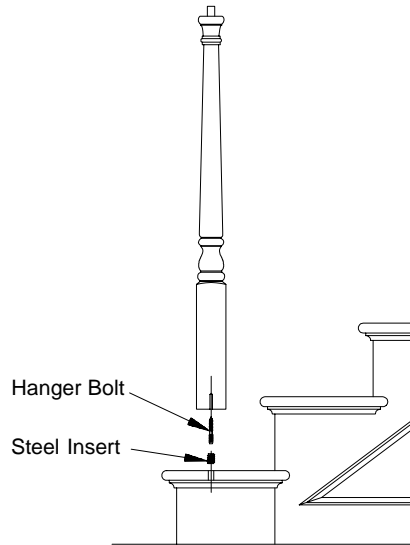

**Note: Various other newel mounting options are described in step 107-B.**

**A, B - GO TO 43 / C, D - GO TO 45**

**43 CALCULATE THE INTERMEDIATE LANDING NEWEL HEIGHT**

To calculate the height of the intermediate landing newel above the level of the landing, refer to the measurements made in steps 41, 18 and 27. The newel height equals:

$$\begin{array}{ccccccc}
 \boxed{\phantom{000}} & \text{PLUS} & \boxed{\phantom{000}} & \text{MINUS} & \boxed{\phantom{000}} & \text{EQUALS} & \\
 \text{From Step 41} & + & \text{From Step 27} & - & \text{From Step 18} & = & \\
 \end{array}$$

**Note: This dimension does not include the pin at the top of the newel nor any part of the bottom block which extends below the level of the landing.**

**GO TO 44**

**44 TRIM AND FASTEN THE INTERMEDIATE LANDING NEWEL**

Trim the intermediate landing newel using the dimension obtained in step 43. Review step 107-A for newel notching instructions. Fasten the newel by running LJ-3078 Rail and Post Fasteners through the face of the newel into the stringers.

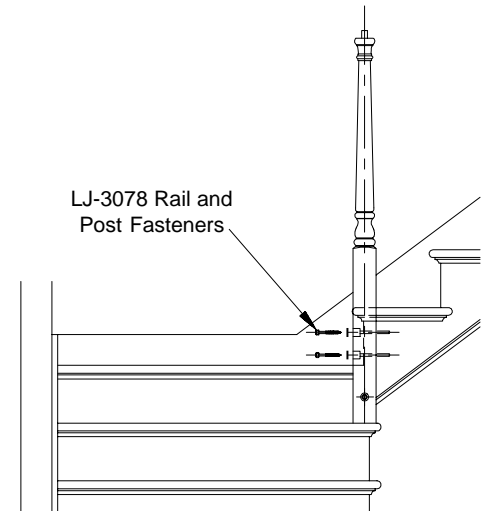

**Note: Various other newel mounting options are described in step 107-B.**

**GO TO 45**

**45 CALCULATE THE BALCONY NEWEL HEIGHT**

To calculate the height of the balcony newel above the balcony, refer to the balcony handrail height determined in step 3.

The height of the newel above the level of the balcony equals:

$$\begin{array}{ccccccc}
 \boxed{\phantom{000}} & \text{MINUS} & \boxed{\phantom{000}} & \text{EQUALS} & \\
 \text{From Step 3} & - & \text{Level Handrail Thickness} & = & \\
 \end{array}$$

**Note: This dimension does not include the pin at the top of the newel nor any part of the bottom block which extends below the level of the balcony.**

**GO TO 46**

46

**TRIM AND FASTEN THE BALCONY NEWEL**

Trim the balcony newel using the dimension obtained in step 45. Review step 107-A for newel notching instructions. Fasten the newel by running LJ-3078 Rail and Post Fasteners through the face of the newel into the balcony fascia and header.

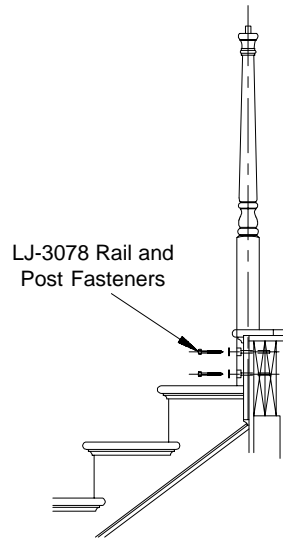

**Note: Various other newel mounting options are described in step 107-B.**

**GO TO 47**

47

**SET THE ENTIRE HANDRAIL SYSTEM ON THE NEWELS**

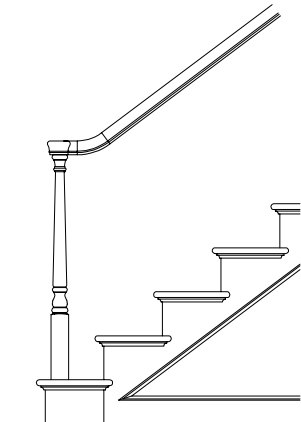

Set the handrail system on the newels. Do not bolt the fittings to the newels at this time.

**GO TO 81**

48

**CLAMP THE HANDRAIL ON THE KNEEWALL OR TREAD NOSING**

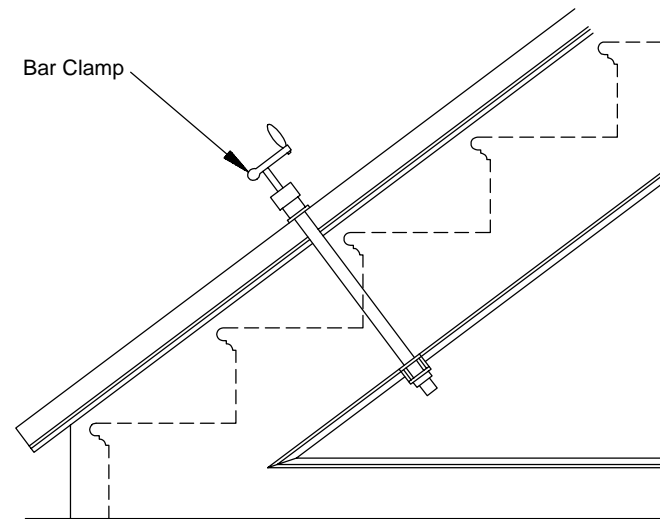
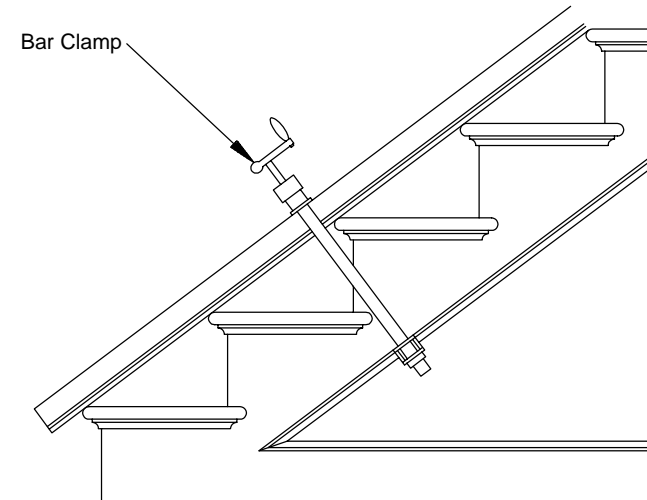

Clamp the handrail to the kneewall, or tread nosing, depending upon the construction of the stair. Use bar clamps on each flight. Locate the handrail directly over the balustrade centerline.

**GO TO 49**

49

**MARK THE POINTS WHERE THE HANDRAIL WILL INTERSECT THE NEWELS**

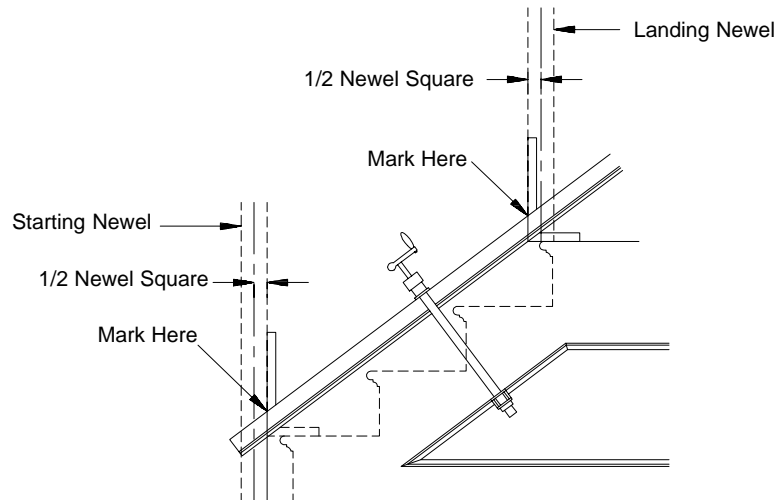
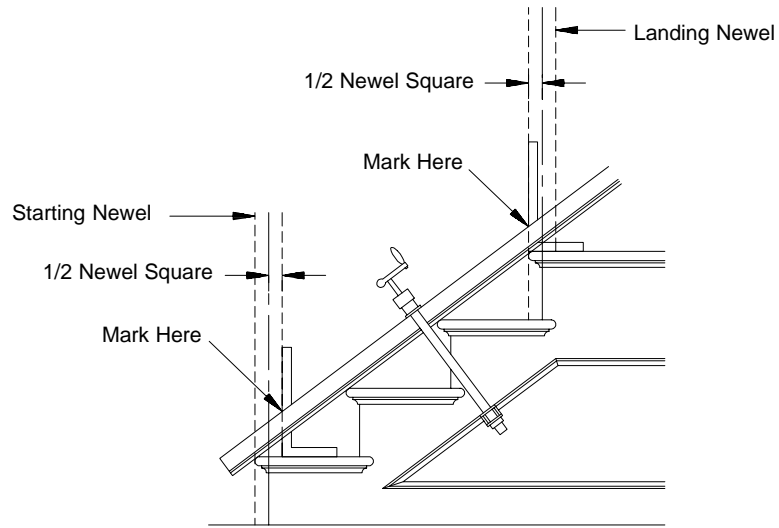

Use a framing square to mark the points where the handrail will intersect the newel. The vertical edge of the square should be 1/2 the newel square (i.e.: 1-1/2" for a 3" newel) from the newel centerpoint. Mark both ends of each flight.

**GO TO 50**

50

**MEASURE THE HEIGHT OF THE HANDRAIL ABOVE THE TREAD NOSING**

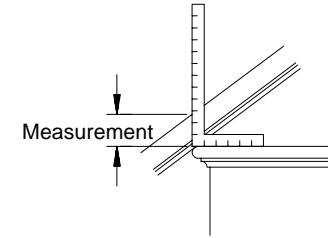

Measure the height of the handrail above the tread nosing while clamped to the treads or kneewall. Be sure the framing square is sitting on a tread and is lined up with the nosing. Write this measurement down.

MEASUREMENT

**GO TO 51**

51

**MEASURE THE HEIGHT OF THE STARTING NEWEL INTERSECTION**

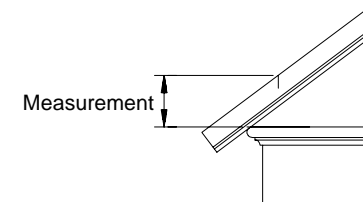

Measure the height from the first tread of the stair to the point where the handrail intersects the starting newel. Write this measurement down.

MEASUREMENT

**DO YOU HAVE A LANDING?  
YES - GO TO 52 / NO - GO TO 53**

52

**MEASURE THE HEIGHT OF THE INTERMEDIATE LANDING NEWEL INTERSECTION**

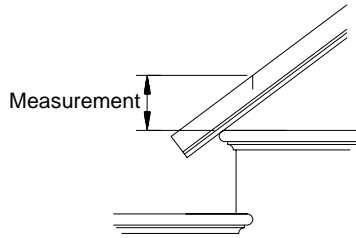

At the intersection of the second flight handrail and the intermediate landing newel, measure the height off of the first tread of the second flight. Write this measurement down.

MEASUREMENT

**GO TO 53**

53

**CALCULATE THE HEIGHT OF THE STARTING NEWEL**

To calculate the measurement from the top of the first tread to the top of the upper block of the starting newel, refer to measurements made in steps 3, 50 and 51.

**Note: This measurement does not include the turned top nor any part of the bottom block which extends below the first tread.**

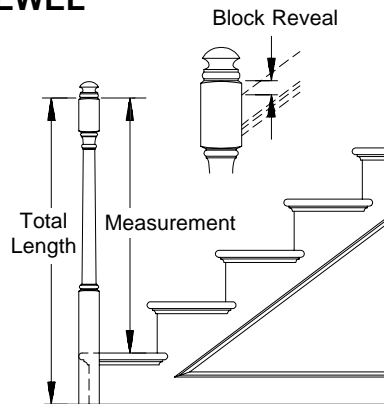

	MINUS		PLUS		PLUS	1"	MEASUREMENT	
Rake Handrail Height From Step 3	-	From Step 50	+	From Step 51	+	Block Reveal		

**E, F - GO TO 54 / G, H - GO TO 55**

54

**TRIM AND FASTEN THE STARTING NEWEL**

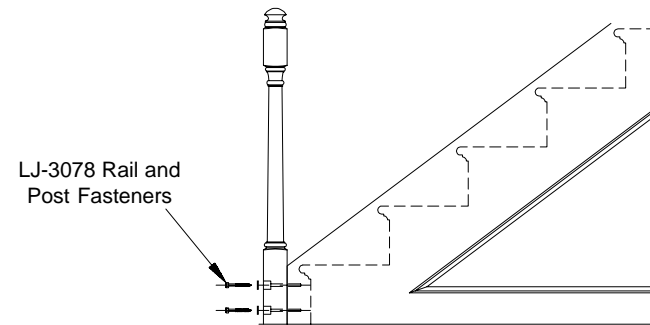

Trim the newel to length using the calculations from step 53. Fasten the starting newel to the kneewall with LJ-3078 Rail and Post Fasteners.

**Note: Various other newel mounting options are described in step 107-B.**

**DO YOU HAVE A LANDING?  
YES - GO TO 56 / NO - GO TO 59**

55

**TRIM AND FASTEN THE STARTING NEWEL**

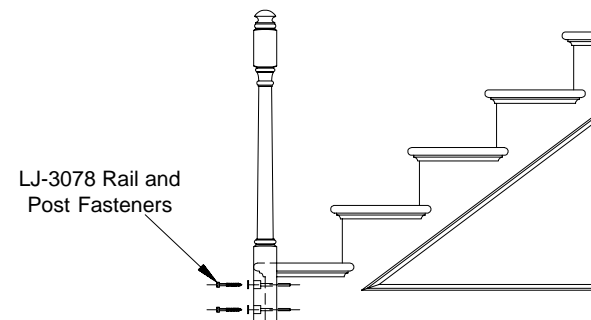

Trim the newel to length using the calculations from step 53. Review step 107-A for newel notching instruction. Fasten the starting newel to the stringer with LJ-3078 Rail and Post Fasteners.

**Note: Various other newel mounting options are described in step 107-B.**

**DO YOU HAVE A LANDING?  
YES - GO TO 56 / NO - GO TO 59**

56

**CALCULATE THE HEIGHT OF THE INTERMEDIATE LANDING NEWEL**

To calculate the measurement from the top of the first tread of the second flight to the top of the upper block of the newel, refer to the measurements made in steps 3, 50 and 52.

**Note: This measurement does not include the turned top nor any part of the bottom block which extends below the level of the first tread of the second flight of stairs.**

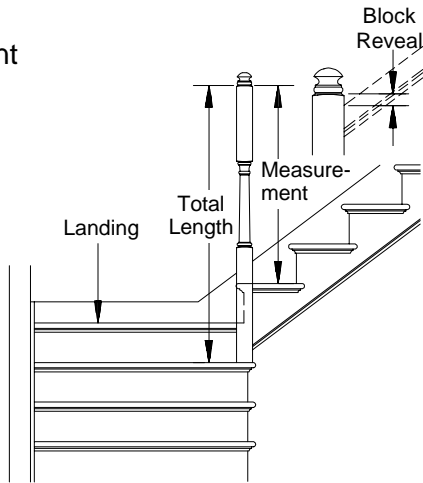

$$\boxed{\phantom{000}} \text{ MINUS } \boxed{\phantom{000}} \text{ PLUS } \boxed{\phantom{000}} \text{ PLUS } \boxed{1"} \text{ TOTAL LENGTH } \boxed{\phantom{000}}$$

Rake Handrail Height From Step 3 - From Step 50 + From Step 52 + Block Reveal

**E, F - GO TO 57 / G, H - GO TO 58**

57

**TRIM AND FASTEN THE INTERMEDIATE LANDING NEWEL**

Trim the intermediate landing newel to length using the calculations made in step 56. Fasten the newel to the second flight kneewall with LJ-3078 Rail and Post Fasteners.

**Note: Various other newel mounting options are described in step 107-B.**

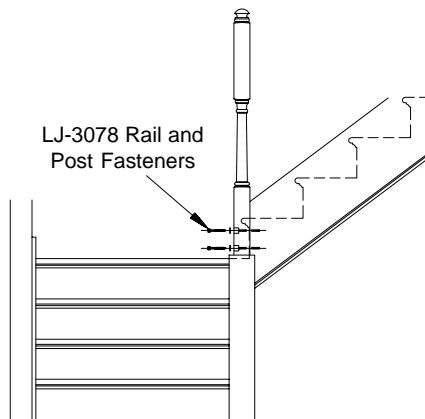

**GO TO 59**

58

**TRIM AND FASTEN THE INTERMEDIATE LANDING NEWEL**

Trim the intermediate landing newel to length using the calculations made in step 56. Review step 107-A for newel notching instructions. Fasten the newel to the stringers of both flights using LJ-3078 Rail and Post Fasteners.

**Note: Various other newel mounting options are described in step 107-B.**

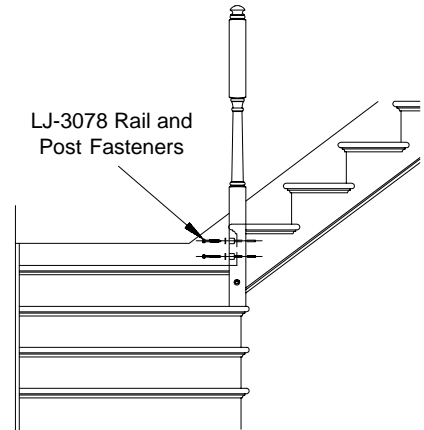

**GO TO 59**

59

**CALCULATE THE HEIGHT OF THE BALCONY NEWEL**

To calculate the measurement from the level of the balcony to the top of the upper block of the newel, refer to the balcony handrail height from step 3.

**Note: This measurement does not include the turned top nor any part of the bottom block which extends below the level of the balcony.**

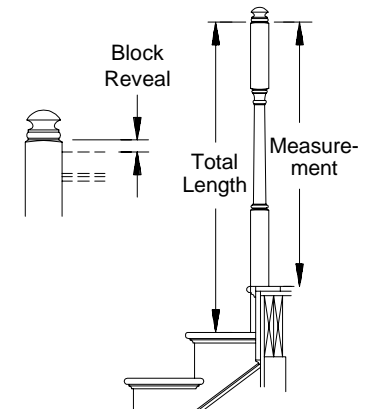

$$\boxed{\phantom{000}} \text{ PLUS } \boxed{1"} \text{ TOTAL LENGTH } \boxed{\phantom{000}}$$

Balcony Handrail Height From Step 3 + Block Reveal

**E, F - GO TO 60 / G, H - GO TO 62**

**60 TRIM AND FASTEN THE BALCONY NEWEL**

Trim the balcony newel to length using the calculations made in step 59. Fasten the newel to the balcony using the LJ-3004 Newel Mounting Hardware.

**Note: Various other newel mounting options are described in step 107-B.**

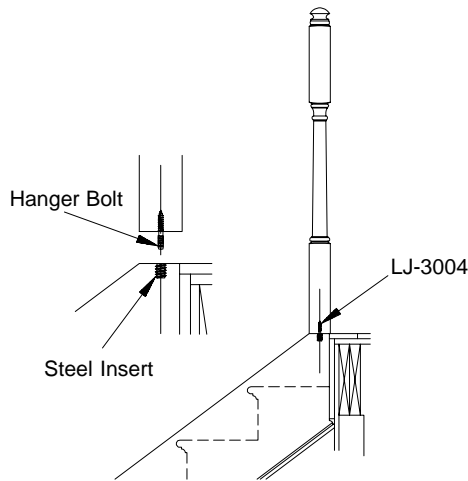

**GO TO 61**

**61 TRIM AND FASTEN THE SHOERAIL**

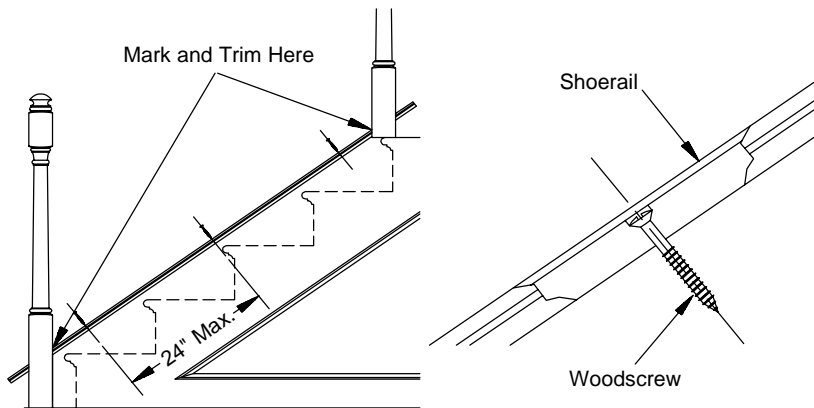

Place the shoerail on the knewall and mark where it intersects the newels. Trim with a miter saw. Fasten the shoerail to the knewall with woodscrews on 16" to 24" centers. Counter sink the woodscrew heads.

**ARE YOU USING FITTINGS?  
YES - GO TO 63 / NO - GO TO 79**

**62 TRIM AND FASTEN THE BALCONY NEWEL**

Trim the balcony newel to length using the calculations made in step 59. Review step 107-A for newel notching instructions. Fasten the newel to the header with LJ-3078 Rail and Post Fasteners.

**Note: Various other newel mounting options are described in step 107-B.**

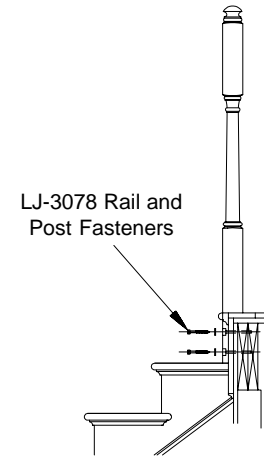

**ARE YOU USING FITTINGS?  
YES - GO TO 63 / NO - GO TO 79**

**63 DO YOU HAVE AN INTERMEDIATE LANDING?  
YES - COMPLETE THIS STEP / NO - GO TO 71**

**MAKE A FITTING SUPPORT BLOCK FOR THE INTERMEDIATE LANDING**

Make a temporary support block out of a 4 x 4 or other material. Refer to the measurement made in step 52. The support block height equals:

$$\boxed{\text{From Step 52}} \text{ MINUS } \boxed{\text{Level Handrail Thickness}}$$

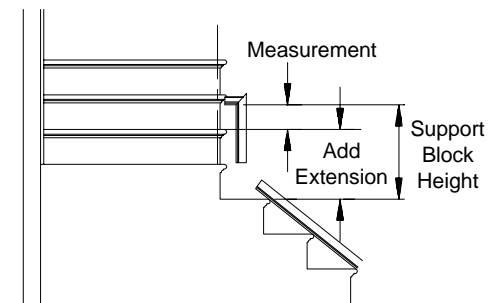

**Note: Add to this the distance the newel extends below the level of the first tread of the second flight.**

**SUPPORT BLOCK HEIGHT**

**GO TO 64**

64

**MARK AND TRIM THE RETURNED END**

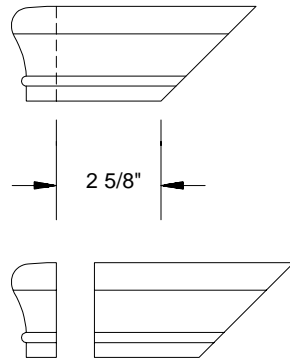

The nose of the returned end must be trimmed in order to be fastened to the newel. Mark the returned end as shown. Trim with a miter saw.

**GO TO 65**

65

**ASSEMBLE THE RAIL DROP TO THE RETURNED END**

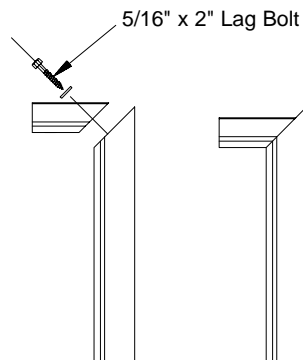

Carefully remove the top lid of the returned end using a putty knife or chisel. Assemble the rail drop to the returned end with a 5/16" x 2" lag bolt and washer.

**GO TO 66**

66

**APPLY A PLYWOOD SEAT TO THE RAIL DROP AND THE FIRST FLIGHT HANDRAIL**

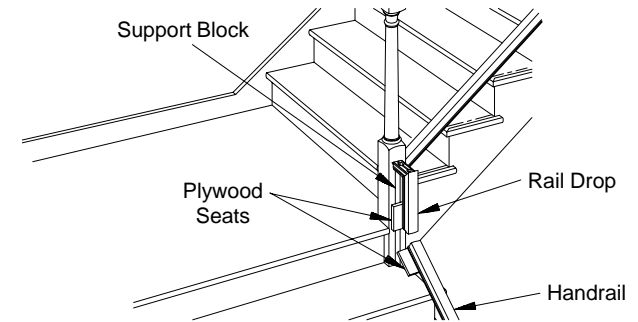

Tack-nail 4"-6" wide pieces of plywood to the underside of the rail drop and to the first flight handrail. This will be used as a temporary seat for marking the rail drop and the handrail for trimming.

**GO TO 67**

67

**MARK THE EASING AT THE TOP OF THE FIRST FLIGHT**

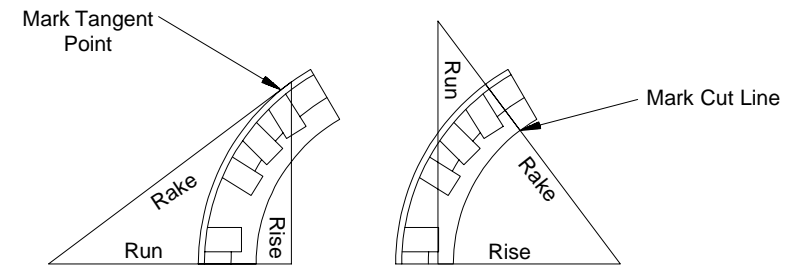

**Always trim the end of the easing which has three pockets.** Stand the easing up on a level surface. Mark the tangent point on the easing with the "run" leg of the pitchblock lying flat. Mark the cut line on the easing with the "rise" leg of the pitchblock lying flat.

**Note: See step 107-E for instructions on how to make a pitchblock.**

**GO TO 68**

68

**TRIM THE EASING AT THE TOP OF THE FIRST FLIGHT**

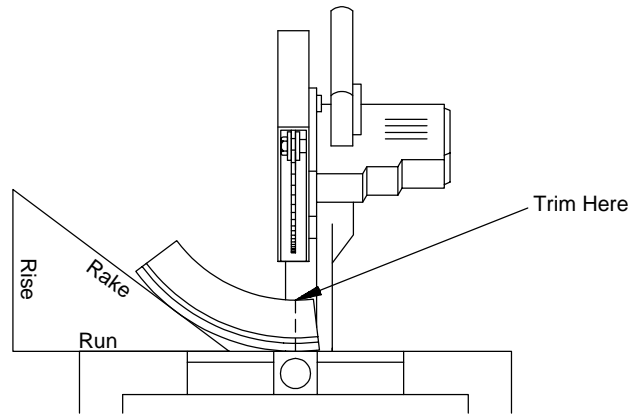

Trim the easing along the cut line using a miter saw. A pitchblock may be used for support, as shown.

**GO TO 69**

69

**MARK AND TRIM THE RAIL DROP AND THE FIRST FLIGHT HANDRAIL**

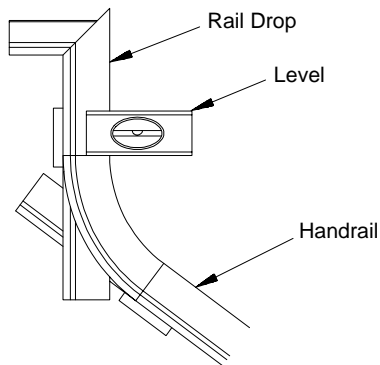

Place the trimmed easing on the plywood seats beside the rail drop and the handrail. Use a torpedo level or LJ-3037 Rail Fitting Level to level the upper end of the easing. Mark the rail drop and the handrail as shown. Trim the rail drop and the handrail at these marks using a miter saw.

**GO TO 70**

70

**ASSEMBLE THE EASING TO THE RAIL DROP AND THE FIRST FLIGHT HANDRAIL**

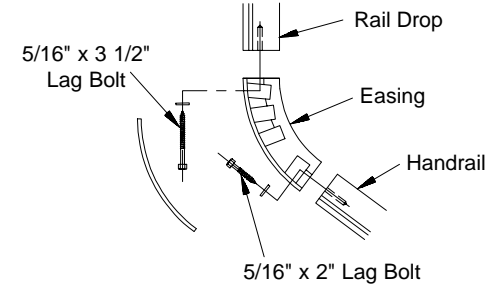

Use the Rail Marking Template to mark the rail drop and the handrail. Drill a 1/4" x 1-1/2" deep pilot hole in the rail drop and the handrail. Assemble the **single pocket end** of the easing to the handrail with a 5/16" x 2" lag bolt and washer. Assemble the **trimmed end** of the easing to the rail drop with a 5/16" x 3-1/2" lag bolt and washer.

**GO TO 71**

71

**MAKE A FITTING SUPPORT BLOCK FOR THE BALCONY**

Make a temporary support block from a 4 x 4 or other material. Refer to the measurement made in step 50. The support block height equals:

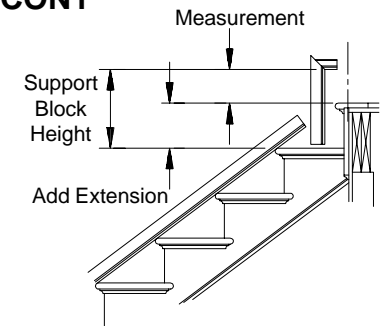

$$\begin{array}{ccccccc}
 \square & \text{MINUS} & \square & \text{PLUS} & \square & \text{MINUS} & \square \\
 \text{Balcony} & & \text{Rake Handrail} & & \text{From Step 50} & & \text{Level Handrail} \\
 \text{Handrail Height} & - & \text{Height From} & + & & - & \text{Thickness} \\
 \text{From Step 3} & & \text{Step 3} & & & & 
 \end{array}$$

**Note: Add to this the distance the newel extends below the level of the balcony.**

SUPPORT BLOCK HEIGHT

**GO TO 72**

**72**

**MARK AND TRIM THE RETURNED END**

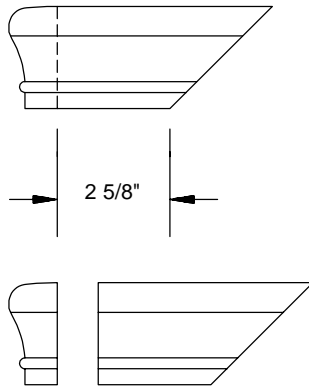

The nose of the returned end must be trimmed in order to be fastened to the newel. Mark the returned end as shown. Trim with a miter saw.

**GO TO 73**

**73**

**ASSEMBLE THE RAIL DROP TO THE RETURNED END**

Carefully remove the lid of the returned end using a putty knife or chisel. Assemble the rail drop to the returned end with a 5/16" x 2" lag bolt and washer.

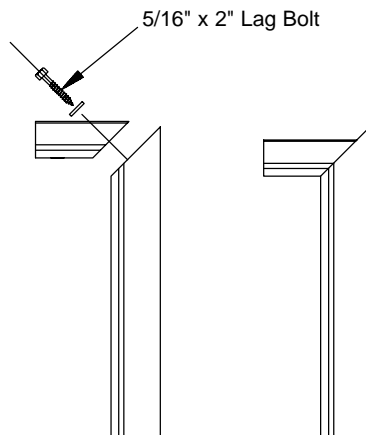

**GO TO 74**

**74**

**APPLY A PLYWOOD SEAT TO THE RAIL DROP AND THE STAIR HANDRAIL**

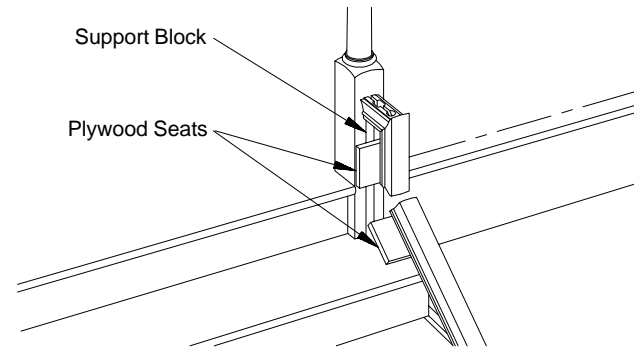

Tack-nail 4"-6" wide pieces of plywood to the underside of the rail drop and the stair handrail. This will be used as a temporary seat for marking the rail drop and handrail for trimming.

**GO TO 75**

**75**

**MARK THE EASING AT THE TOP OF THE FLIGHT**

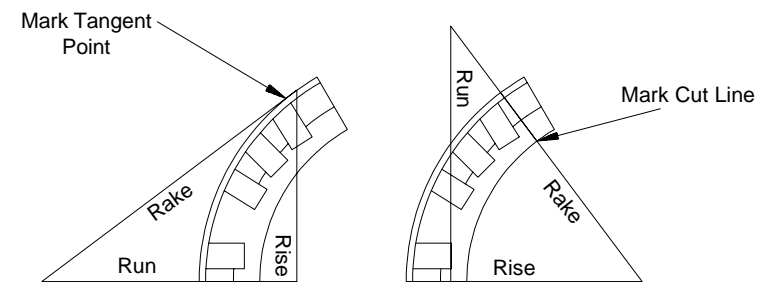

**Always trim the end of the easing which has three pockets.** Stand the easing up on a level surface. Mark the tangent point on the easing with the "run" leg of the pitchblock lying flat. Mark the cut line on the easing with the "rise" leg of the pitchblock lying flat. **Note: See step 107-E for instructions on how to make a pitchblock.**

**GO TO 76**

76

**TRIM THE EASING AT THE TOP OF THE FLIGHT**

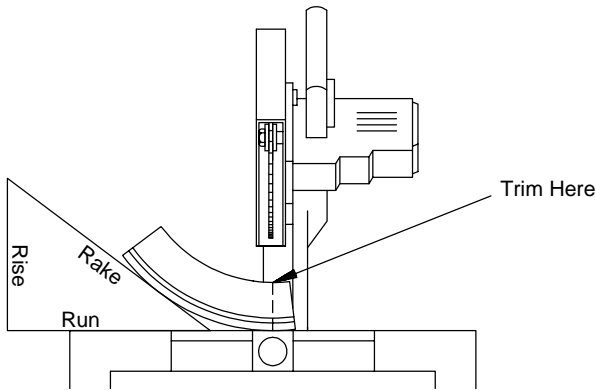

Trim the easing along the cut line using a miter saw. A pitchblock may be used for support, as shown.

**GO TO 77**

77

**MARK AND TRIM THE RAIL DROP AND THE STAIR HANDRAIL**

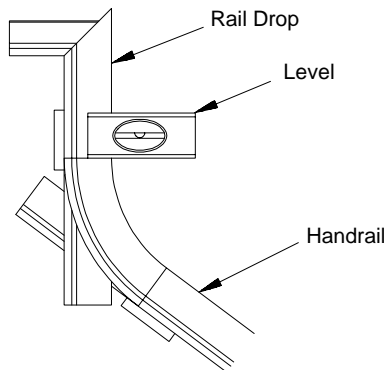

Place the trimmed easing on the plywood seats beside the rail drop and the stair handrail. Use a torpedo level or LJ-3037 Rail Fitting Level to level the upper end of the easing. Mark the rail drop and the stair handrail as shown. Trim the rail drop and the handrail at these marks using a miter saw.

**GO TO 78**

78

**ASSEMBLE THE EASING TO THE RAIL DROP AND THE STAIR HANDRAIL**

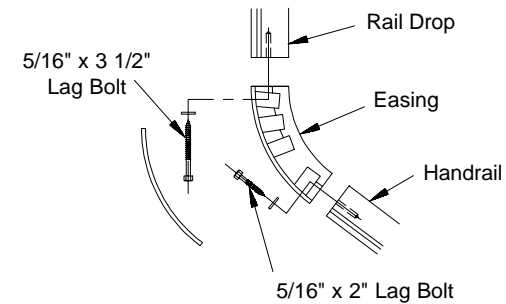

Use the Rail Marking Template to mark the rail drop and the stair handrail. Drill a 1/4" x 1-1/2" deep pilot hole in the rail drop and the handrail. Assemble the **single pocket end** of the easing to the stair handrail with a 5/16" x 2" lag bolt and washer. Assemble the **trimmed end** of the easing to the rail drop with a 5/16" x 3-1/2" lag bolt and washer.

**GO TO 79**

79

**TRIM THE HANDRAIL TO LENGTH**

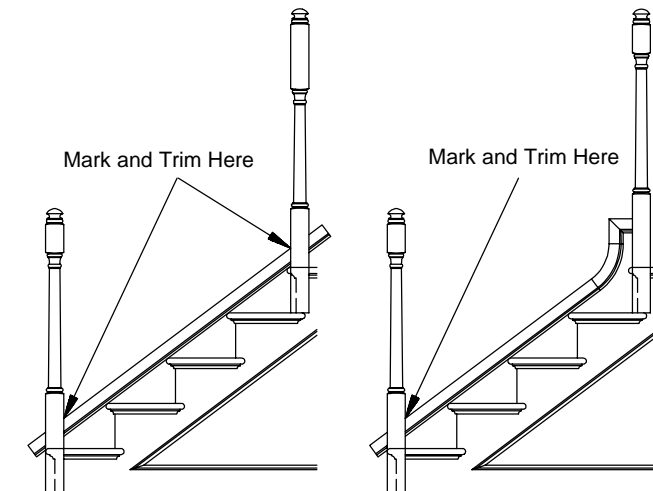

Lay the handrail on the kneewall or tread nosings. Mark the points where it intersects the newels. Trim with a miter saw.

**E, F, G, H - GO TO 80**

80

**TEMPORARILY FASTEN THE HANDRAIL TO THE NEWELS**

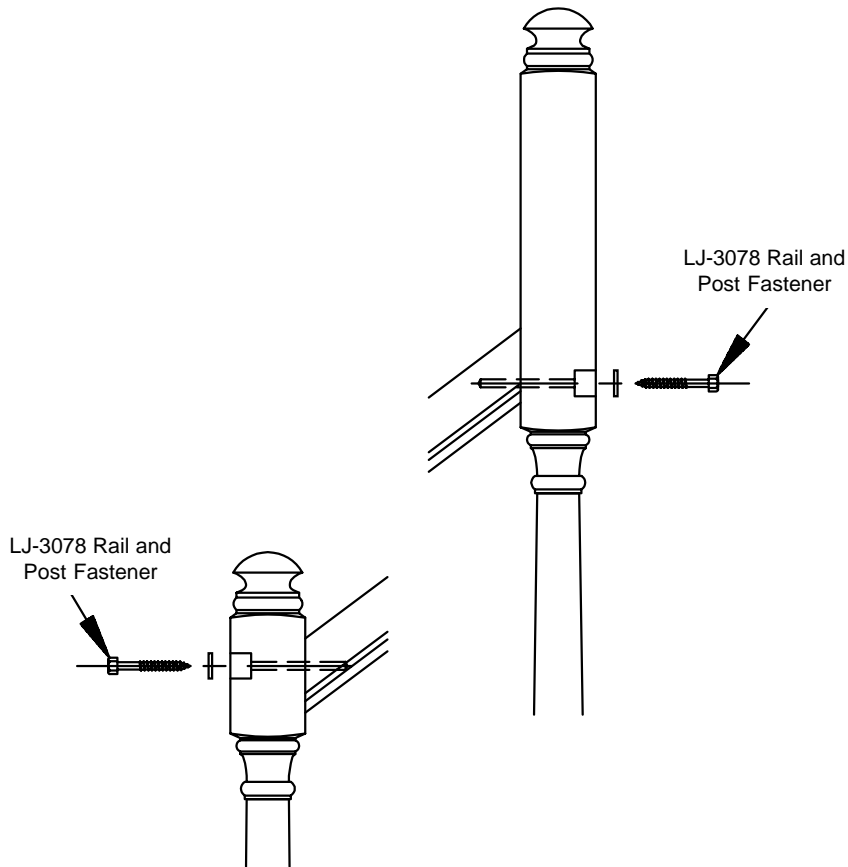

Use LJ-3078 Rail and Post Fasteners to **TEMPORARILY** fasten the handrail to the newels.

**Note:** Do not use glue or plugs at this time.

**GO TO 81**

81

**MARK THE BALUSTER CENTERLINES ON THE HANDRAIL**

Use the LJ-3047 Telescoping Baluster Marking Tool to transfer the baluster centers to the handrail, following instructions included with the tool.

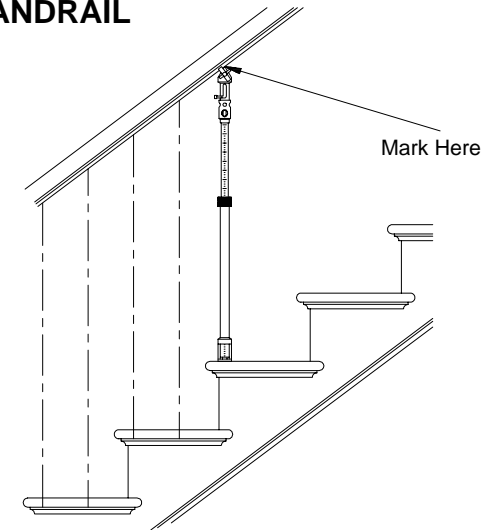

**Note:** See step 107-L for alternatives to the LJ-3047 Telescoping Baluster Marking Tool.

**A, B, C, D, G, H - GO TO 82 / E, F - GO TO 86**

82

**TAP HOLES IN THE TREADS FOR THE BALUSTERS**

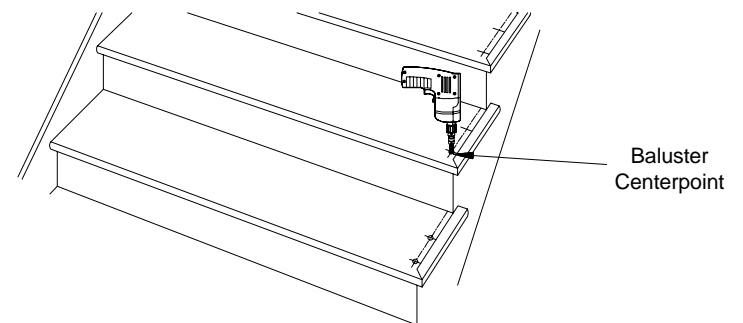

Use the LJ-3036 Dowel-Fast Tap to tap holes in the treads for the balusters. Tap holes at the baluster centerpoints, following instructions included with the hardware. **Note:** See step 107-M for alternatives to the LJ-3076 Dowel-Fast and LJ-3036 Dowel-Fast Tap.

**A, B, C, D, G, H - GO TO 83**

83

TRIM THE BALUSTERS TO LENGTH

PIN TOP BALUSTERS

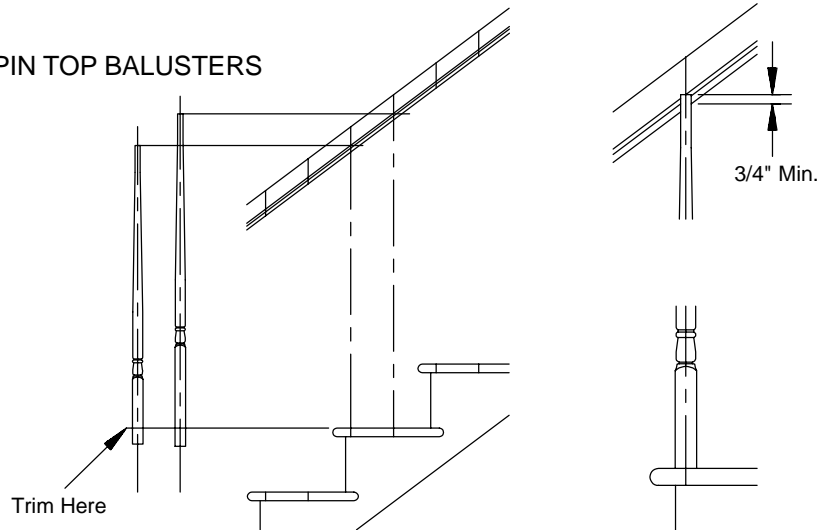

SQUARE TOP BALUSTERS

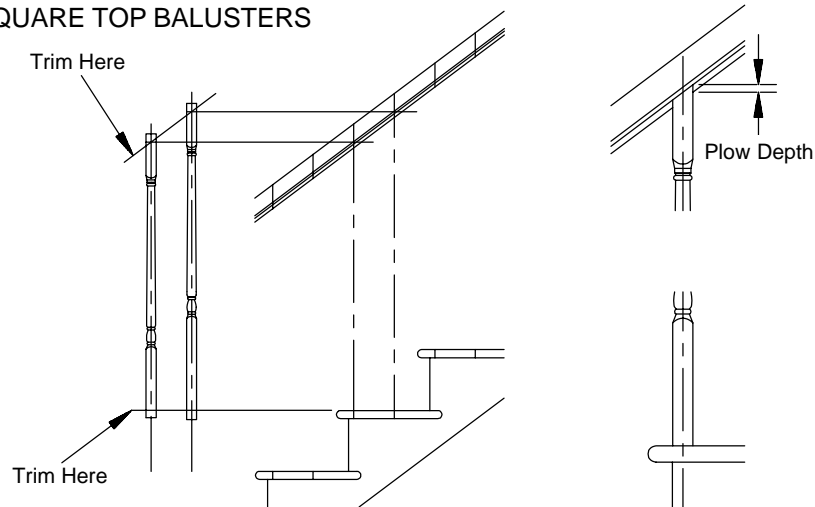

Measure the baluster length required. Square cut the bottom blocks as required.

**For pin top balusters: Allow for 3/4" insertion into the handrail.**

**For square top balusters: Allow for insertion into the handrail plow.**

GO TO 84

84

DRILL A PILOT HOLE IN THE BOTTOM OF THE BALUSTERS

All balusters are pre-drilled with a 9/32" diameter pilot hole to a minimum of 4" deep. If too much of the pilot hole has been trimmed away, drill a pilot hole using the LJ-3035 Centaur drill guide to ensure proper centering.

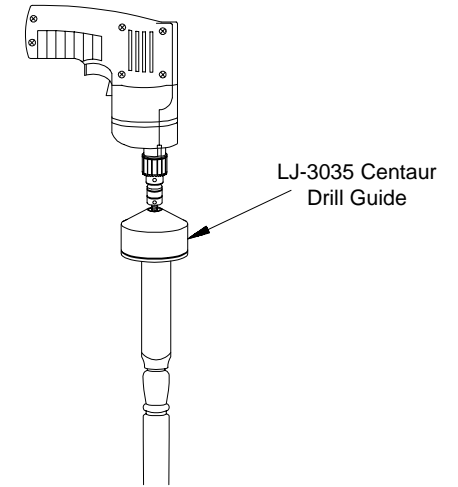

GO TO 85

85

INSERT THE DOWEL-FAST INTO THE BOTTOM OF THE BALUSTERS

Use the LJ-3033 Dowel Runner to insert the LJ-3076 Dowel-Fast screws into the bottoms of the balusters, following instructions included with the hardware.

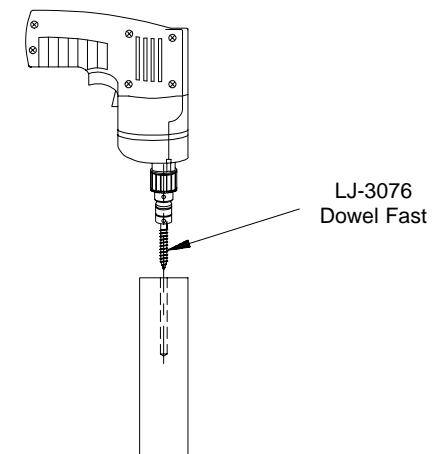

A, C, G - GO TO 88 / B, D, H - GO TO 87

TRIM THE BALUSTERS TO LENGTH

PIN TOP BALUSTERS

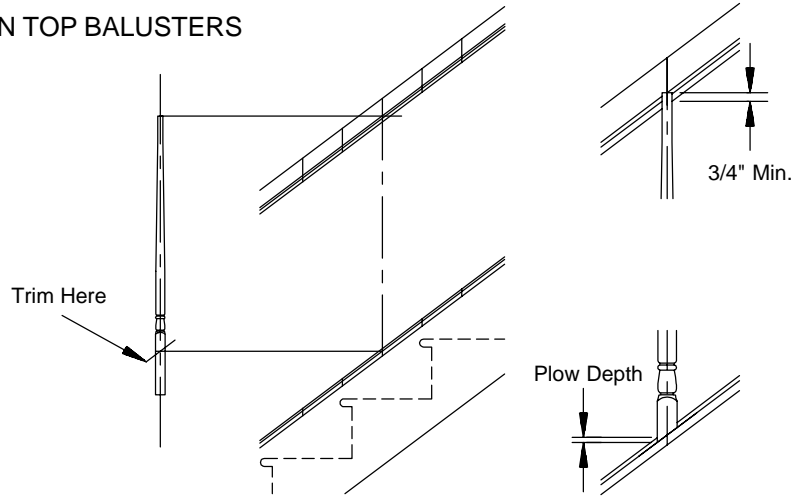

SQUARE TOP BALUSTERS

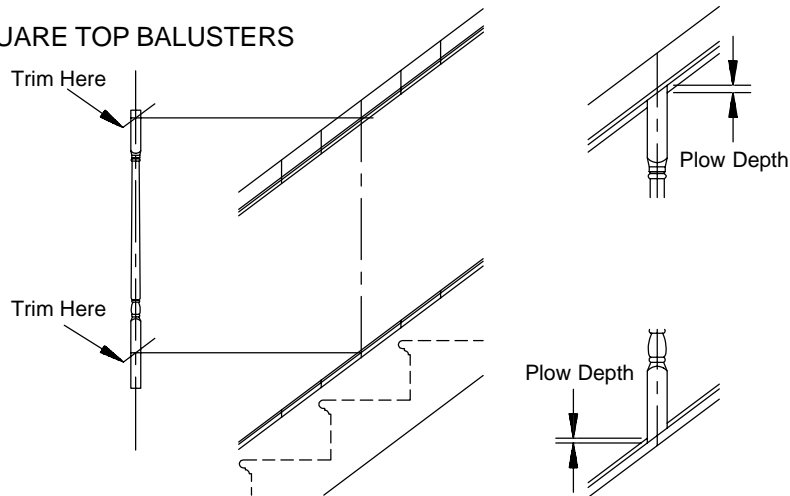

Measure the baluster length required. Miter cut the bottom blocks as required. Allow for insertion into the shoerail plow.

**Note:** To achieve a longer bottom block, trim the top of the baluster as desired.

**For pin top balusters:** Allow for 3/4" insertion into the handrail.

**For square top balusters:** Allow for insertion into the handrail plow.

E - GO TO 89 / F - GO TO 87

DRILL BALUSTER HOLES IN THE HANDRAIL

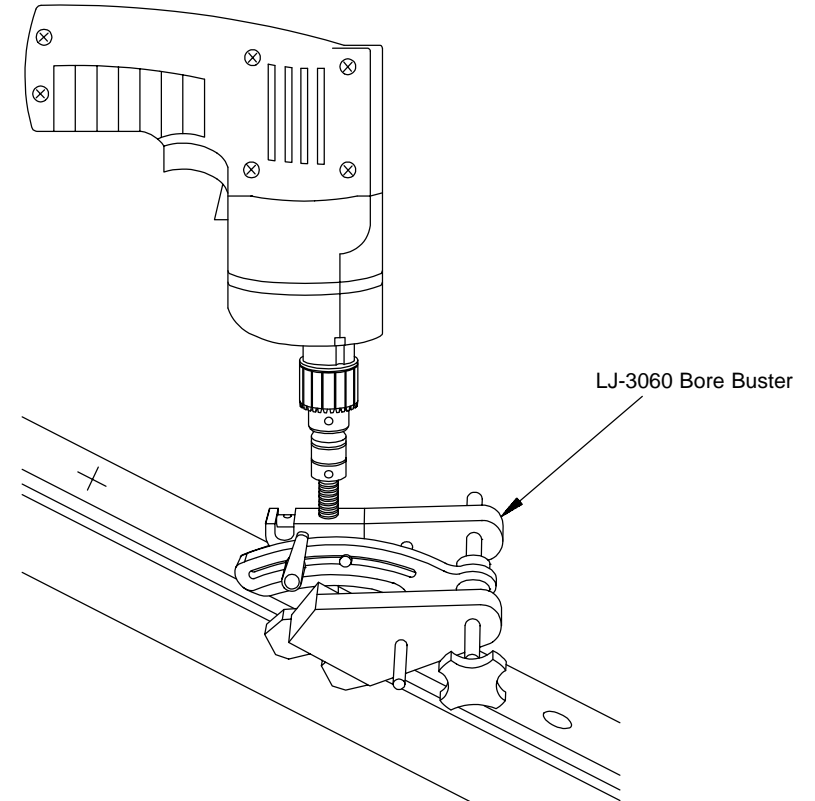

Use the LJ-3060 Bore Buster drill guide to drill baluster holes in the handrail. Use the instructions provided with the tool.

**Note:** See step 107-N for alternatives to the LJ-3060 Bore Buster.

B, D, H - GO TO 88 / F - GO TO 89

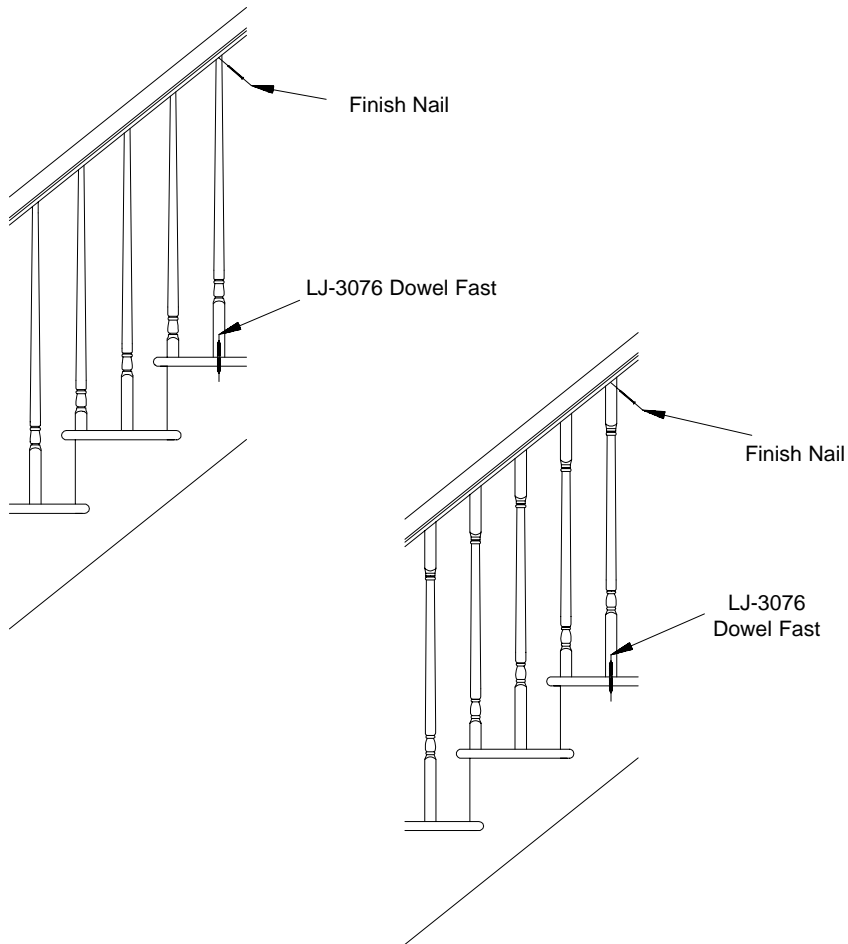

Fasten the balusters to the treads using the LJ-3076 Dowel-Fast screws. Fasten the balusters to the handrail with finish nails and adhesive. The handrail should be permanently fastened to the newels at this time.

**A, C, G - GO TO 91**  
**B, D - ARE YOU USING A HALF NEWEL?**  
**YES - GO TO 92 / NO - GO TO 98**  
**H - ARE YOU USING A HALF NEWEL?**  
**YES - GO TO 95 / NO - GO TO 98**

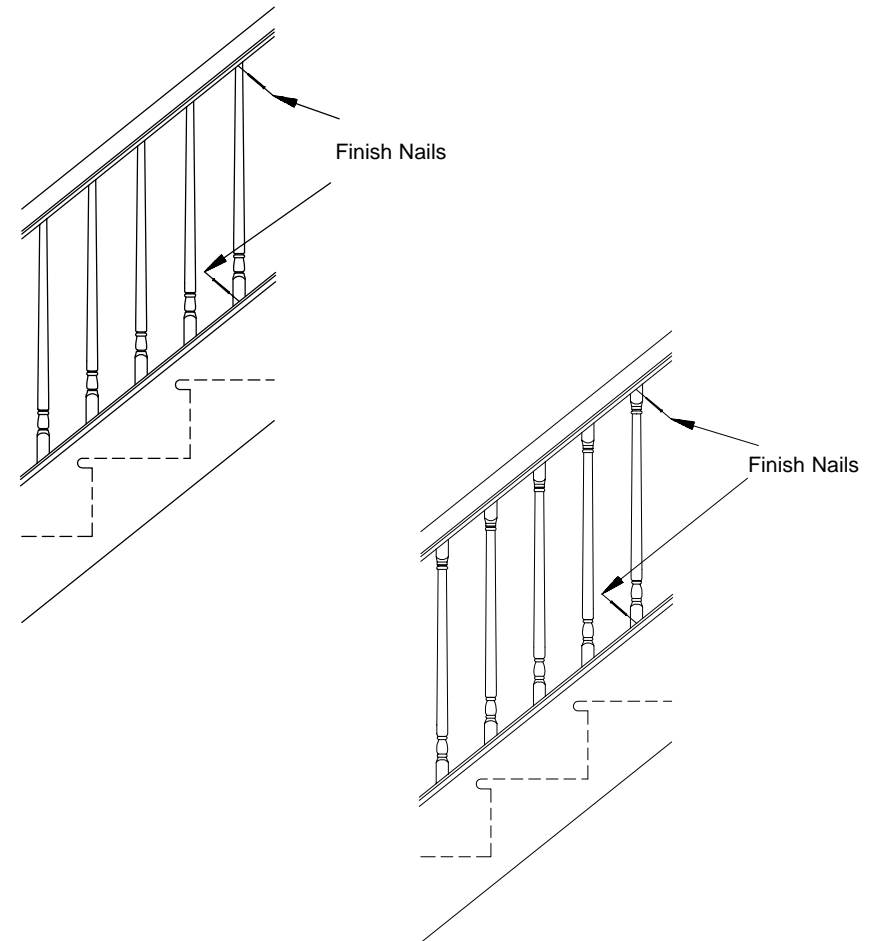

The handrail should be permanently fastened to the newels at this time. Fasten the balusters to the shoerail and handrail with finish nails and adhesive.

**GO TO 90**

**90** **INSTALL FILLET IN THE SHOERAIL**

Place the fillet on the shoerail beside the balusters to mark it to length. Trim the fillet with a miter saw and fasten with finish nails and adhesive.

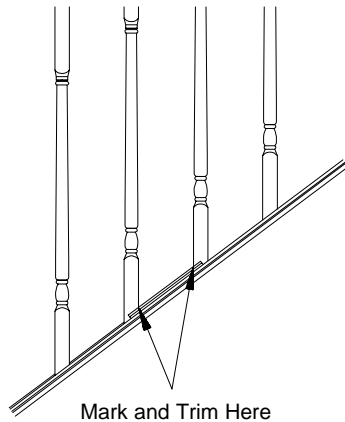

**E - GO TO 91**  
**F - ARE YOU USING A HALF NEWEL?**  
**YES - GO TO 95 / NO - GO TO 98**

**91** **INSTALL FILLET IN THE HANDRAIL**

Place the fillet against the handrail beside the balusters to mark it to length. Trim the fillet with a miter saw and fasten with finish nails and adhesive.

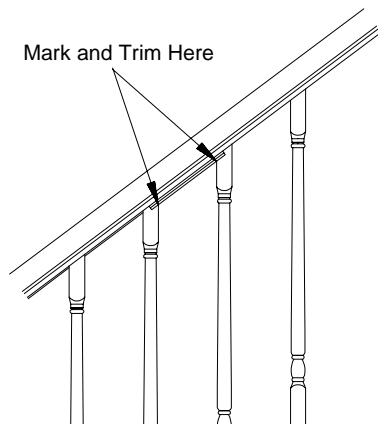

**A, C - ARE YOU USING A HALF NEWEL?**  
**YES - GO TO 92 / NO - GO TO 98**  
**E, G - ARE YOU USING A HALF NEWEL?**  
**YES - GO TO 95 / NO - GO TO 98**

**92** **FASTEN THE HALF NEWEL TO THE WALL**

Trim the half newel to the height of the balcony newel and locate it against the wall on the balcony balustrade centerline. Fasten the half newel to the wall with LJ-3078 Rail and Post Fasteners, finish nails and construction adhesive. Toggle bolts are recommended if a wall stud is not available.

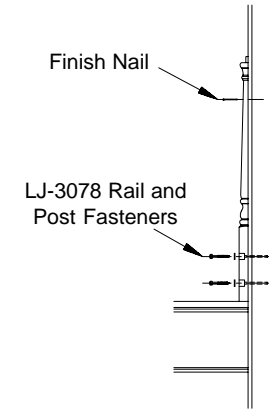

**GO TO 93**

**93** **TRIM THE OPENING CAP AND FASTEN TO THE HANDRAIL**

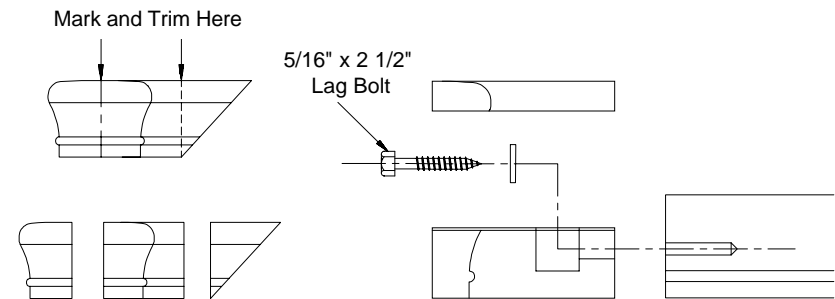

Use a miter saw to square cut the mitered end of the opening cap, as shown. Trim the opening cap in half, as shown. Drill a 1/4" x 1-1/2" deep pilot hole in the balcony handrail using the Rail Marking Template. Carefully remove the top lid of the opening cap using a putty knife or chisel. Fasten the square cut end of the opening cap to the balcony handrail with a 5/16" x 2-1/2" lag bolt and washer.

**GO TO 94**

94

**TRIM THE BALCONY HANDRAIL TO LENGTH AND FASTEN TO THE BALCONY FITTING**

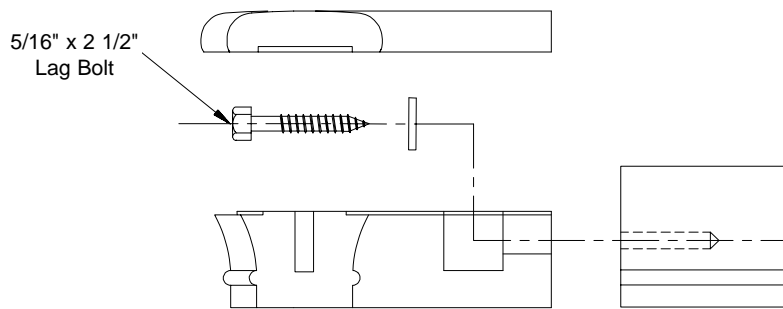
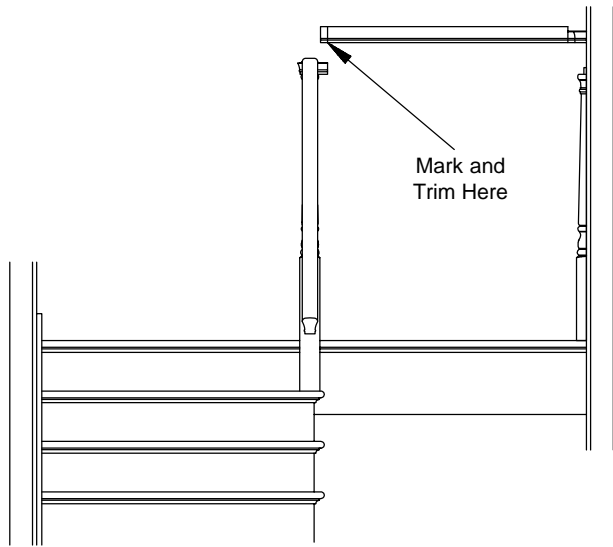

Trim the balcony handrail to length. Drill a 1/4" x 1-1/2" pilot hole in the handrail using the Rail Marking Template. **Temporarily** fasten the handrail to the balcony gooseneck assembly with a 5/16" x 2-1/2" lag bolt and washer.

**GO TO 104**

95

**TRIM THE BALCONY HANDRAIL TO LENGTH**

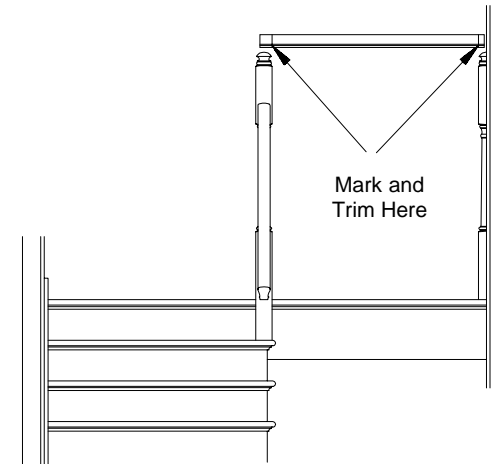

Trim the half newel to the height of the balcony newel. **Temporarily** set it in place against the wall. Mark and trim the balcony handrail to length.

**GO TO 96**

96

**ASSEMBLE THE HALF NEWEL TO THE BALCONY HANDRAIL AND FASTEN TO THE WALL**

Attach the half newel to the balcony handrail with a LJ-3078 Rail and Post Fastener. Counterbore the back of the half newel to accept the bolt head. **Temporarily** attach the half newel to the wall with LJ-3078 Rail and Post Fasteners.

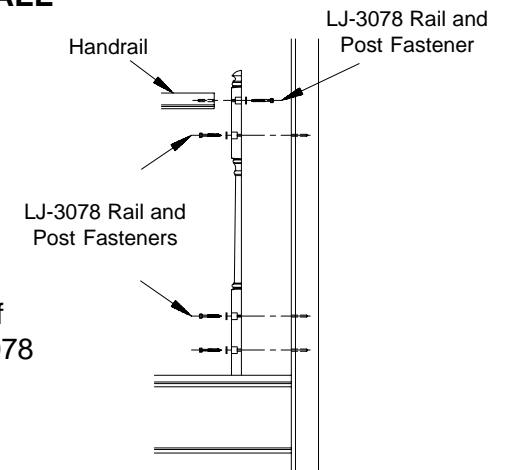

**GO TO 97**

**97 FASTEN THE BALCONY HANDRAIL TO THE BALCONY NEWEL**

Trim the balcony handrail to length. **Temporarily** fasten the balcony handrail to the balcony newel using the LJ-3075 Flush Mount Kit, following the instructions included with the hardware.

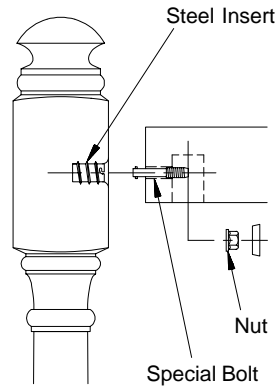

**GO TO 104**

**98 FASTEN THE ROSETTE TO THE BALCONY HANDRAIL**

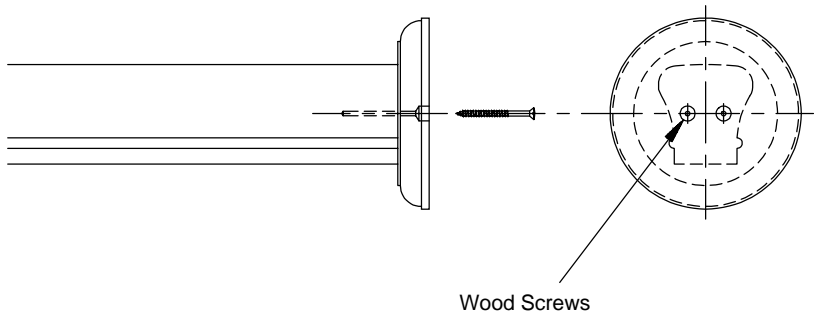

Fasten a rosette to the balcony handrail with two wood screws and adhesive. The screws must be countersunk to allow the rosette to seat properly against the wall.

**A, B, C, D, - GO TO 99 / E, F, G, H - GO TO 101**

**99 TRIM THE BALCONY HANDRAIL TO LENGTH**

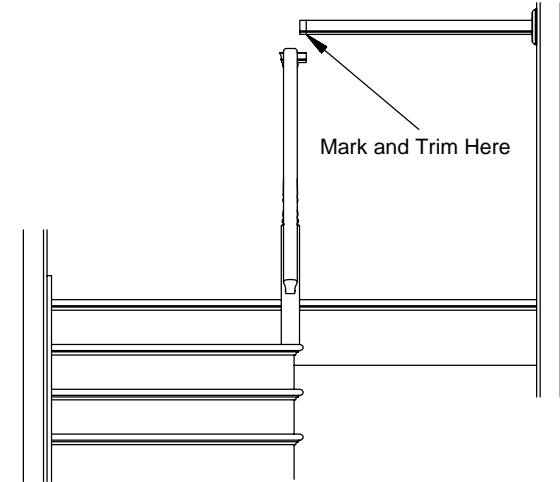

Trim the balcony handrail to length.

**GO TO 100**

**100 FASTEN THE BALCONY HANDRAIL TO THE BALCONY FITTING**

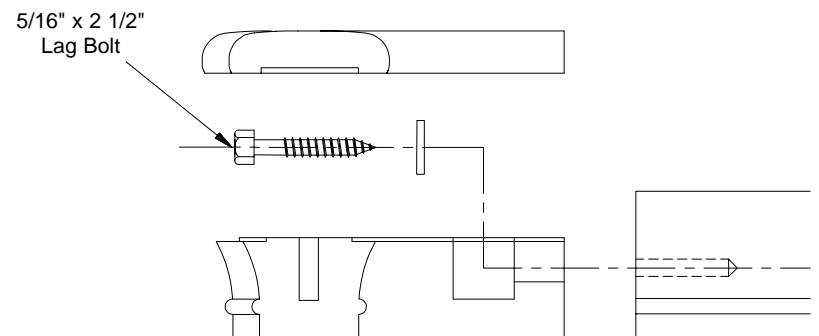

Drill a 1/4" x 1-1/2" deep pilot hole in the balcony handrail using the Rail Marking Template. **Temporarily** fasten the balcony handrail to the balcony gooseneck assembly with a 5/16" x 2-1/2" lag bolt and washer.

**GO TO 103**

101

**TRIM THE BALCONY HANDRAIL TO LENGTH**

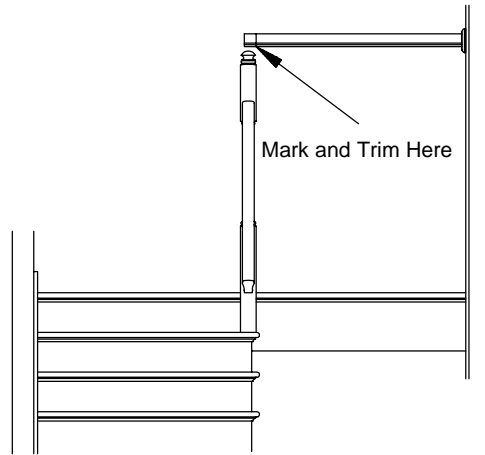

Trim the balcony handrail to length.

**GO TO 102**

102

**FASTEN THE BALCONY HANDRAIL TO THE BALCONY NEWEL**

Temporarily fasten the balcony handrail to the balcony newel using the LJ-3075 Flush Mount Kit, following the instructions included with the hardware.

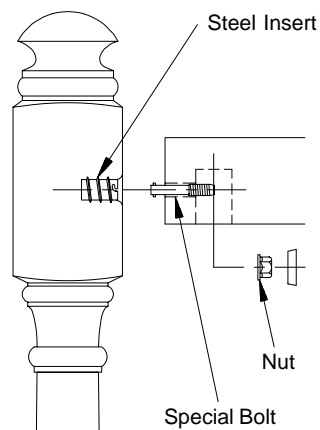

**GO TO 103**

103

**TEMPORARILY FASTEN THE ROSETTE TO THE WALL**

**Note:** Because the balcony handrail may have to be removed for baluster installation, do not permanently fasten the rosette to the wall at this time.

**ALTERNATIVE 1:**

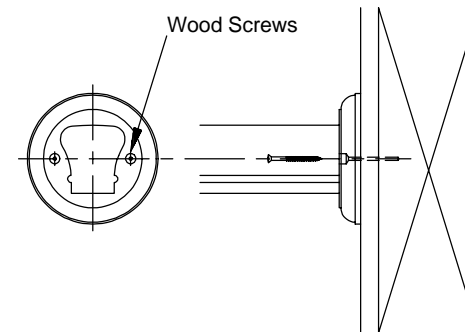

It is very important to securely fasten the rosette to the wall. The recommended method is to run wood screws through the rosette into a wall stud. The screws should be countersunk.

**ALTERNATIVE 2:**

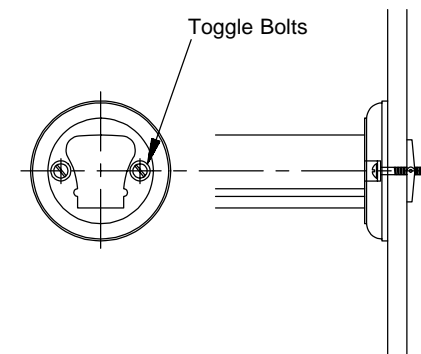

An optional method uses two toggle bolts, secured through the drywall if a stud is not available.

**GO TO 104**

**COMPLETE THE INSTALLATION OF ALL BALCONY PARTS**

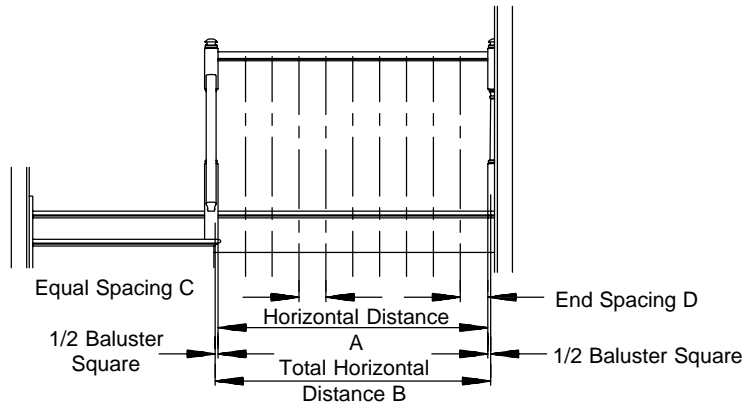

Work through the following equations to determine the proper center-to-center baluster spacing. Use the End Spacing obtained in Equation number 4 and the Equal Spacing obtained in Equation number 3. Mark the points on the floor and double check that they add up to the Total Horizontal Distance. See the Quick Reference Index, step **108**, which lists those steps required for baluster, shoerail and fillet installation.

**EQUAL SPACING CENTER -TO-CENTER (C):**

Equation 1  +  =   
 (A) Horizontal Distance      Size of one Baluster Square      (B) Total Horizontal Distance

Equation 2  ÷  =   
 (B) Total Horizontal Distance      Spacing Required by Code      Number of Spaces (Round up)

Equation 3  ÷  =   
 (B) Total Horizontal Distance      Number of Spaces      (C) Equal Spacing Center-to-Center

**END SPACING (D) From face of Newel to Center of First Baluster):**

Equation 4  -  =   
 (C) Equal Spacing Center-to-Center      1/2 Baluster Square      (D) End Spacing

**DECIMAL TO FRACTIONAL CONVERSIONS:**

The following examples will help in converting the decimals in the previous equations to fractions. Assume your equal spacing from Equation 3 is 5.1724. Determine whether you want to measure to the closest 1/16, 1/32 or 1/64. Disregard the whole number - use only .1724.

For the nearest 1/16" measurement, multiply by 16:  
 .1724 x 16 = 2.7584; round to 3 = equal spacing of **5 3/16"**

For the nearest 1/32" measurement, multiply by 32:  
 .1724 x 32 = 5.5168; round to 6 = equal spacing of **5 6/32"**

For the nearest 1/64" measurement, multiply by 64:  
 .1724 x 64 = 11.0336; round to 11 = equal spacing of **5 11/64"**

**ARE YOU USING FITTINGS?  
 YES - GO TO 105 / NO - GO TO 106**

**ASSEMBLE LIDS TO ALL FITTINGS**

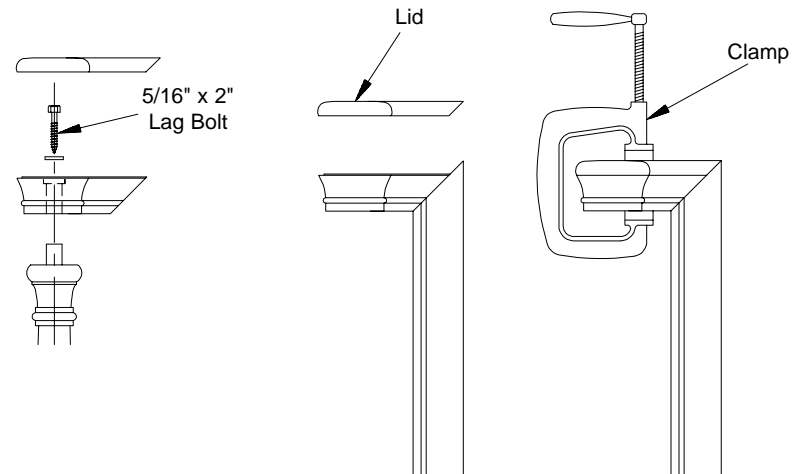

Assemble lids to all Conect-A-Kit fittings using the instructions provided with the parts.

**GO TO 106**

**NOTE: FINISH MUST BE APPLIED WITHIN 24 HOURS OF PRODUCT DELIVERY TO THE JOBSITE!**

It is important that all parts be lightly sanded before finishing. Any excess glue or oil from human hand can mar the evenness of the stair finish. Be sure all dust is removed to ensure a smooth finish.

Apply stain to a piece of wood as a test piece. This will help determine how much stain to apply and how long to leave it on the wood before wiping off any excess. The color may vary somewhat depending on various properties of the wood, such as end grain. Stain should be wiped on in small areas, then wiped off to desired darkness after no more than two minutes. Follow the recommendations of the stain manufacturer.

After staining is complete and allowed to dry, apply finish. Polyurethane finishes provide the best protection and a fine finish as well as rapid drying time. After each finish coat is completely dry, buff lightly with steel wool (0000 grade) or 220 grit sand paper. Try this first on a test piece or an inconspicuous area to determine how much pressure to use to avoid damage. Next, remove debris left from buffing by wiping with a tack cloth. Generally, two or three coats of finish are required. Follow the recommendations of the finish manufacturer.

A fine furniture wax is normally recommended.

**Note: It is critical to apply finish to all sides of all parts, including hidden surfaces, to minimize the gain or loss of moisture.**

**107-A NEWEL NOTCHING**

After the newel centerpoints and heights have been determined, draw the outline of the material to be removed on the newel with a square. Make a rough cut 1/8" to 1/4" away from the line, using further cuts to carefully pare away material up to the line. Hand chisel any remaining material.

**IMPORTANT: Unless you are experienced at performing this operation, it is recommended that you practice marking and notching on a 4 x 4 or other scrap material. This is especially critical when performing a compound notch, such as that required for an intermediate landing newel.**

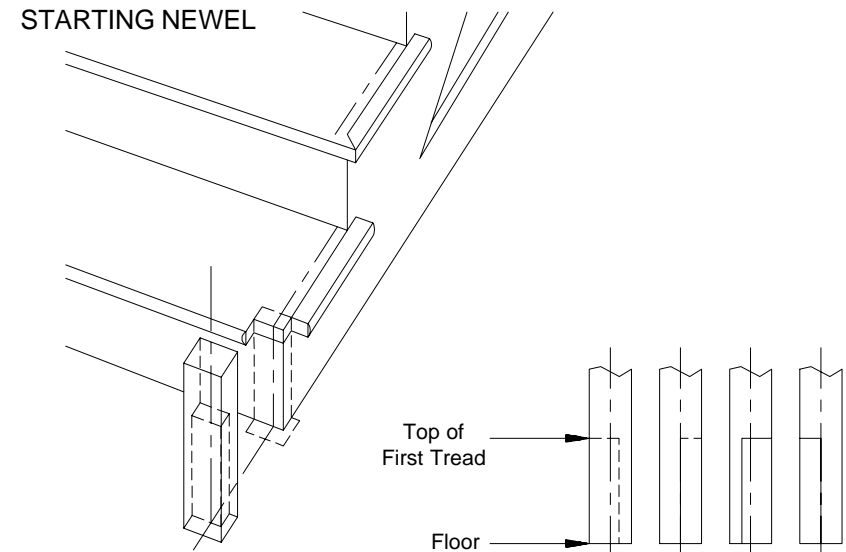

Once notched, the starting newel will sit on the first tread of the stair. It will also drape over the first riser and the stringer. The exact dimensions will depend upon the placement of the newel.



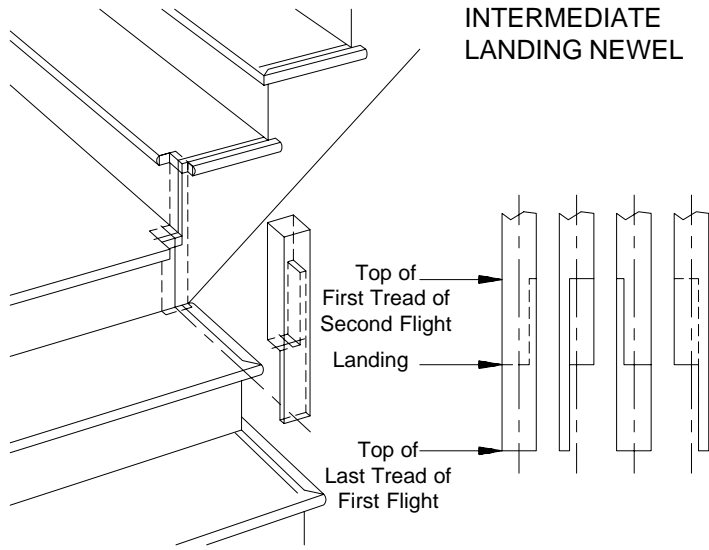

Once notched, the intermediate landing newel will sit on the first tread of the second flight of stairs. It will also drape over the riser and stringer of the landing. From there, it will continue to drape over the landing to the top tread of the first flight of stairs.

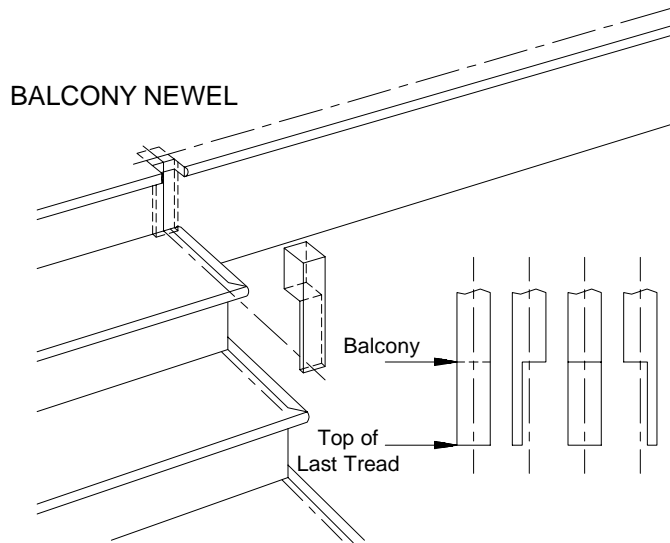

Once notched, the balcony newel will sit on the balcony and drape over the last riser to the last tread of the stairway.

**107-B NEWEL MOUNTING OPTIONS**  
**1-LJ-3004 NEWEL MOUNTING KIT**

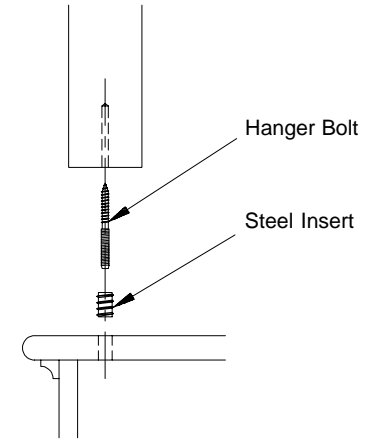

The LJ-3004 Newel Mounting Kit uses a threaded steel insert and a 3/8" x 2" hanger bolt to fasten a newel post to a starting step tread or to a balcony floor.

Detailed installation instructions are included with the LJ-3004 Newel Mounting Kit.

**2-LJ-3005 KEYLOCK NEWEL POST FASTENER**

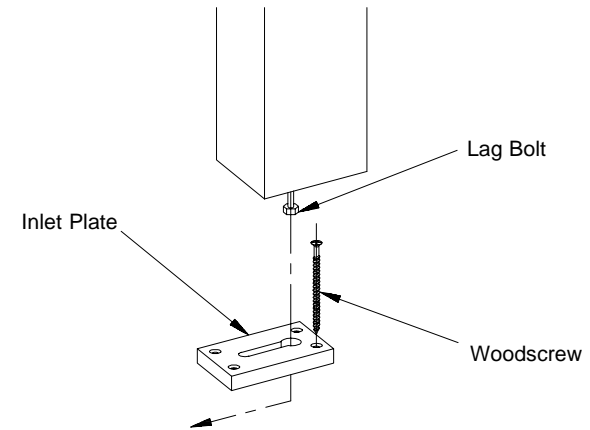

The LJ-3005 Keylock Newel Post Fastener uses a 3/8" x 5" lag bolt and a steel inlet plate to fasten a newel post to a balcony floor.

Detailed installation instructions are included with the LJ-3005 Keylock Newel Post Fastener.



**3-LJ-3006 NEWEL MOUNTING PLATE**

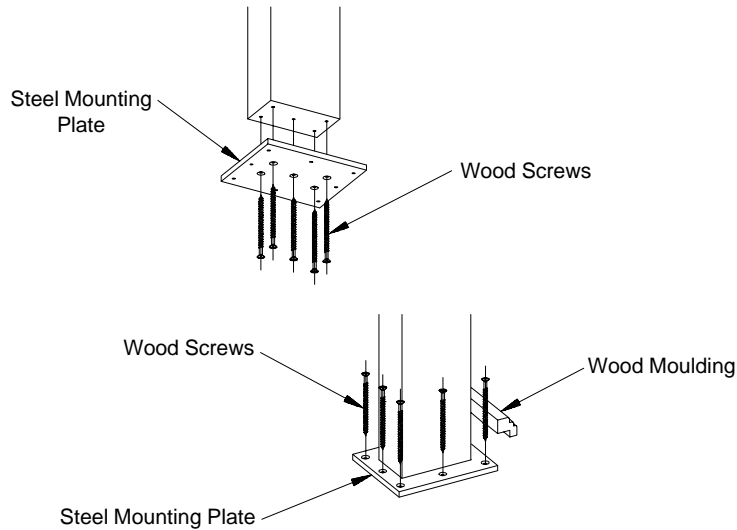

The LJ-3006 Newel Mounting Plate uses a 3/16" steel plate to fasten a newel post to a balcony floor. The plate is then covered with decorative moulding.

Detailed installation instructions are included with the LJ-3006 Newel Mounting Plate.

**4-LJ-3009 NEWEL POST ANCHOR**

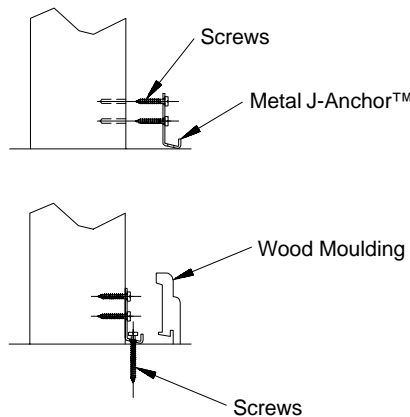

The LJ-3009 Newel Post Anchor uses four 16 gage metal brackets to fasten a newel post to a balcony floor. The brackets are then covered with pre-mitered decorative moulding.

Detailed installation instructions are included with the LJ-3009 Newel Post Anchor.

**5-LJ-3008 SURE-TITE NEWEL FASTENING SYSTEM**

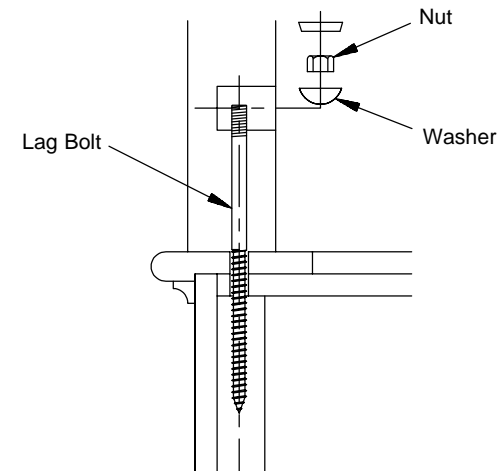

The LJ-3008 Sure-Tite Newel Fastening System uses a 1/2" x 11" or 16" lag bolt to fasten a newel post to a balcony.

Detailed installation instructions are included with the LJ-3008 Sure-Tite Newel Fastening System

**6-LJ-3070 THREADLOCK NEWEL POST FASTENER**

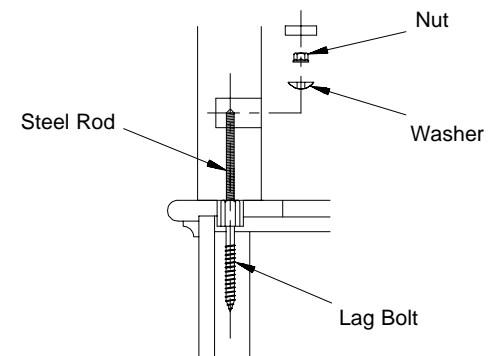

The LJ-3070 Threadlock Newel Post Fastener uses a 1/2" x 5" lag bolt and a 3/8" x 5" steel rod to fasten a newel post to a balcony.

Detailed installation instructions are included with the LJ-3070 Threadlock Newel Post Fastener.



### 7-LJ-3071 TOGGLE BOLT NEWEL MOUNTING KIT

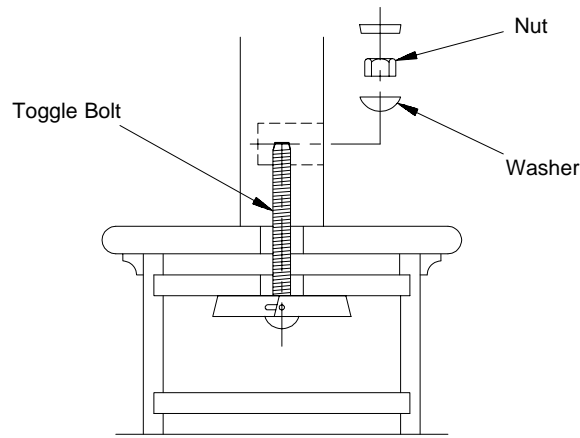

The LJ-3071 Toggle Bolt Newel Mounting Kit uses a 1/2" x 5" toggle bolt to fasten a newel post to a starting step tread.

Detailed installation instructions are included with the LJ-3071 Toggle Bolt Newel Mounting Kit.

### 8-LJ-3078 RAIL AND POST FASTENER

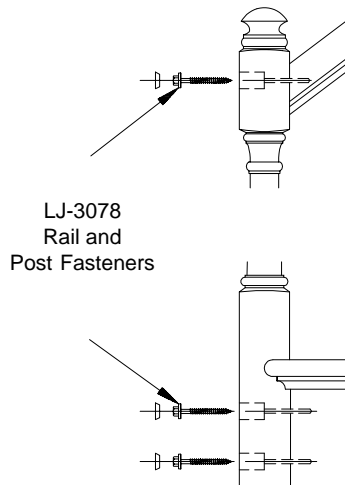

The LJ-3078 Rail and Post Fastener uses a 3/8" x 3" lag bolt to fasten a newel post to a stair carriage. It is also used to fasten square-top newels to handrail.

Detailed installation instructions are included with the LJ-3078 Rail and Post Fastener.

### 107-C FALSE TREAD KIT INSTALLATION

NOTE: More detailed instructions are included with each kit.

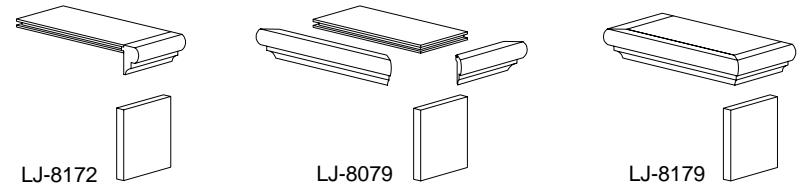

False treads are intended as an economical substitute for standard LJ-8070 Treads and LJ-8075 Risers when a carpet runner is used. **IMPORTANT:** Please read these instructions carefully before beginning installation.

#### PART 1 - Building the Rough Stair

NOTE: If you are using a false bullnose starting step, read Part 6 before cutting the rough horses.

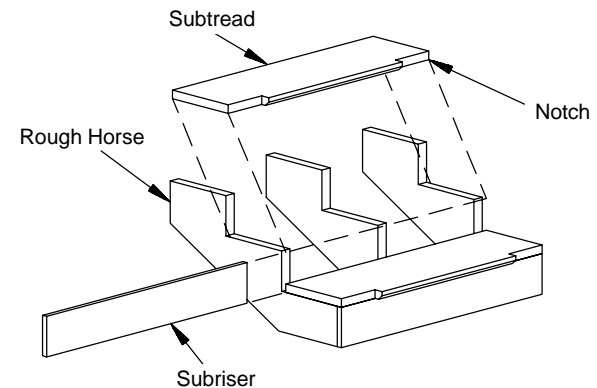

Lay out three rough horses to the required rise and run. Cut the subrisers to the width of the rough stair and install with construction adhesive and screws.

Notch the subtreads 1 1/4" deep and 6" wide to create a false nose on the subtread. If using 2 x 12's, chamfer the bottom edge of this false nose. This will keep the end grain of the false tread moulding from being exposed following installation of carpet. Install the subtreads with construction adhesive and screws.

Install the finished skirtboard on the open side of the stair. Miter cut the rise of the skirt board at 45° to match the false risers.



## PART 2 - Installing False Risers

NOTE: If you are using a false bullnose starting step, read Part 6 before installing false risers.

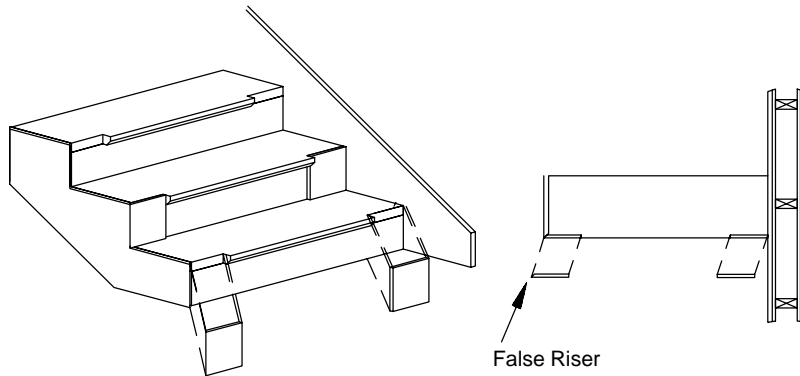

Fit and install the false risers on the closed side of the stair using glue and finish nails. Cut a 45° miter on all false risers for the open side of the stair. Install using glue and finish nails.

## PART 3 - Installing the LJ-8172 False Tread Kit

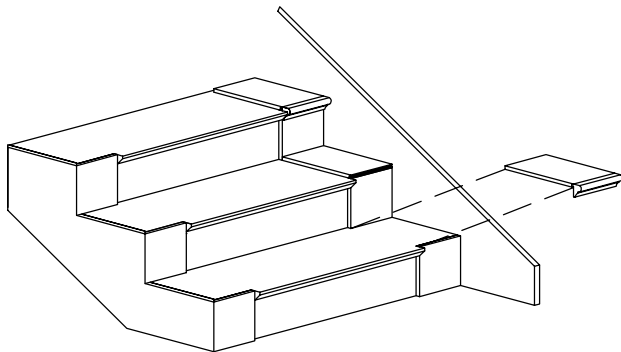

Place the false treads on the closed side of the stair and mark the length needed. NOTE: Always place the tread on the stair with the non-grooved edge toward the middle of the stair. Install the false treads using glue and finish nails.

## PART 4 - Installing the LJ-8079 False Tread Kit

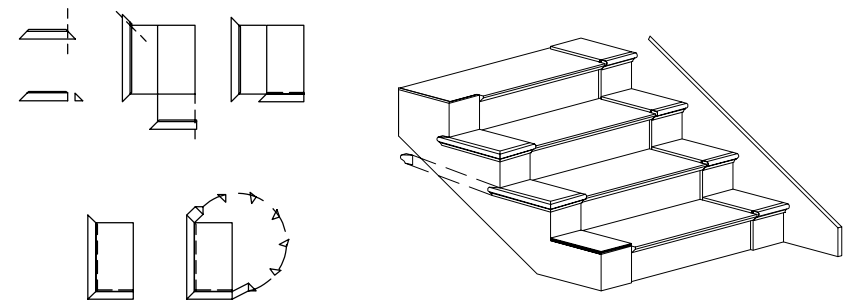

The LJ-8079 False Tread Kit may be used for right or left hand applications. Locate the non-grooved side of the tread toward the middle of the stair. Trim the tread to the run of the stair. Cut the miter from the end of the 9" piece of moulding that will be toward the middle of the stair. Save this piece to use later on the miter return.

Then cut the 9" moulding to fit the width of the tread. Miter cut the 14" piece of moulding to fit the length of the tread. Glue both mouldings to the tread.

Assemble the false treads to the stair using glue and finish nails. Fit and install the miter return to the end of the 14" moulding using glue.

## PART 5 - Installing the LJ-8179 False Tread Kit

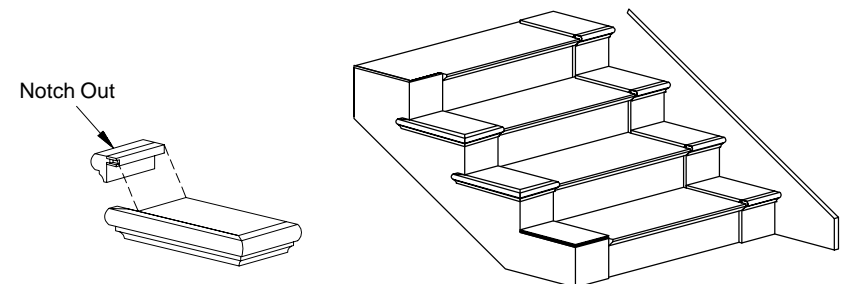

The LJ-8179 False Tread Kit may be used for right or left hand applications. Mark the run of the stair on the tread and cut out the notch using a bandsaw or table saw. There is no need to piece-in the end of the miter return. Install the tread using glue and finish nails.



## PART 6 - Installing the False Bullnose Starting Step

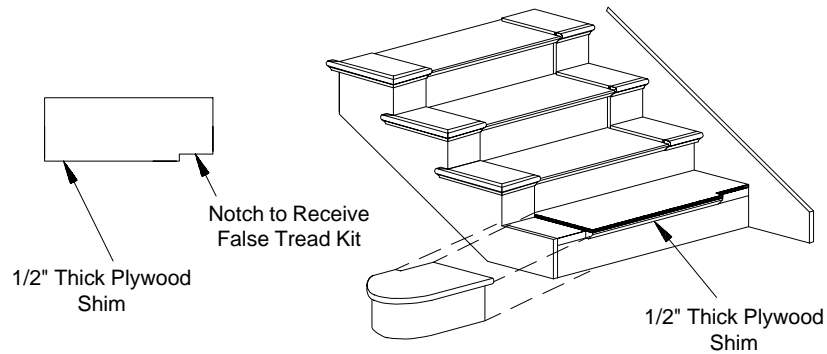

Because the solid tread of a false bullnose starting step is 1" thick and all other false treads are 1/2" thick, the bottom rise should be made 1/2" shorter than the other rises. Prepare a 1/2" thick plywood shim which will be installed on top of the first sub-tread between the bullnose tread and the stringer on the closed side of the stair. The false tread on the closed side will be installed on top of this shim.

Secure the bullnose riser to the stair with glue and screws. Locate the screws where they will be covered by the cove and shoe moulding.

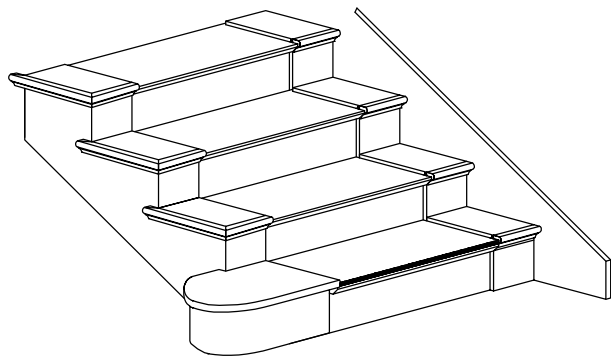

Attach the bullnose tread to the stair using glue and finish nails. Screws should be located where they will be covered by the starting newel.

## 107-D BENDING RAIL INSTALLATION

L.J. Smith Bending Rail is designed for making curved railings on most curved staircases and balconies at the jobsite. Below are conditions that should be met for best results:

### Rake Rails on Staircases

1. The Run, Rise, and Radius must be constant on that part of the stair where bending rail is to be used.
2. The minimum recommended radius to use bending rail successfully is LJ-6010B (30"), LJ-6210B (30"), LJ-6519B (54"), LJ-6109B (36").

### Level Balcony Rails

1. The minimum recommended radius to use bending rail successfully is LJ-6010B (36"), LJ-6210B (36"), LJ-6519B (60"), LJ-6109B (48").

NOTE: Due to the irregularities in wood, it is possible that more than one attempt will be required to bend a tight radius successfully.

## BENDING RAILS

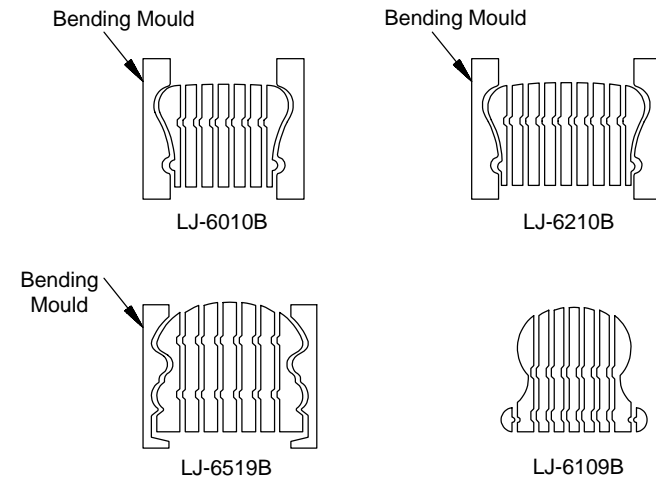

**IMPORTANT:** Please read instructions thoroughly before beginning.

The following steps will provide an accurate and attractive job:

1. Construct the bending forms as shown in illustration #1 below, one for each tread.
2. Measure the total width of the bending rail, including the bending mould, then divide the total width in half to find the centerline of the rail. Mark the centerline of the rail on the bending forms. Cover the treads under the bending area to catch glue drippings. Attach the bending forms to the stair treads, aligning the rail centerline marks over the baluster centerline. Keep the front edge of the bending form flush with the nose of the tread. See illustration #2. Follow a similar procedure around the edge of a curved balcony.

**ILLUSTRATION #1**  
**Bending Form**

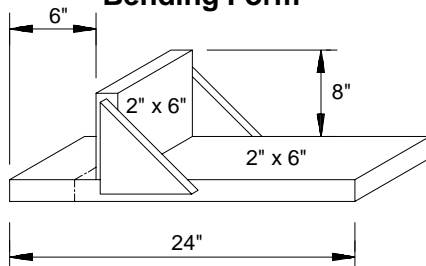

**ILLUSTRATION #2**  
**Top View**

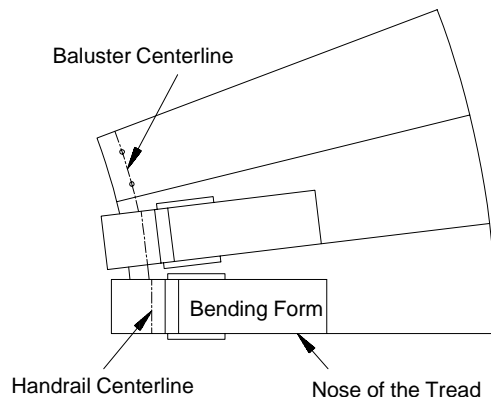

## Preparing & Bending Rail

1. Cover the inside of the bending mould with wax paper or plastic wrap. This will keep the glue from sticking to the mould. When using L.J. Smith LJ-6910BM ENDURO-MOULD this step is eliminated.
2. When a rail is required to be longer than 16', two shorter rails will be spliced together. This splice is made by making a butt joint with each layer of the rail. A 12" long strip of filament tape (or Scotch Wood Joiners No. 0) across each butt joint will hold the pieces together during bending. The joints should be staggered about 24" to prevent a buldge in the rail and provide strength at the joint. See illustration #3.
3. Using a paint roller, put a thin even coat of glue on all contact surfaces of the bending rail. L.J. Smith recommends Franklin Titebond 50 or an equal substitute.

**ILLUSTRATION #3**

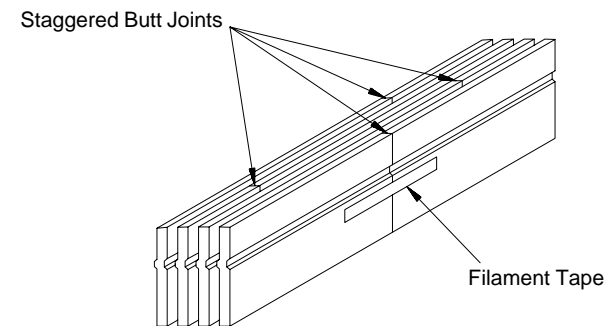

**ILLUSTRATION #4**

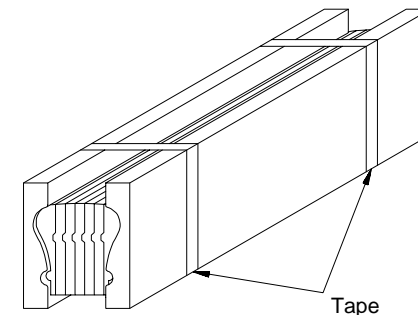

4. Assemble the bending rail in one half of the bending mould as you glue each piece, finishing with the other half of the bending mould.
5. Wrap the bending rail assembly with filament tape about every 4' to hold the rail together while forming it to the curve. See illustration #4.
6. Start forming the rail to the curve by clamping at one end. Gradually pulling the rail to the forms and clamping as you go, work to the other end of the rail. Force the bending rail down on the front edge of each bending form. Put a clamp on each bending form and put clamps on the bending rail in between the forms. Clamps should be no more than 6" apart. It is very important to clamp the rail as closely together as possible to get good glue adhesion and a uniform bend in the rail. See Photos Below.
7. Most handrails are ready to remove from the forms in 24-48 hours. However, when bending a very tight radius, it is advisable to allow additional drying time. Take the rail assembly off of the bending forms and remove the bending mould. Remove the excess glue with a hand belt sander.
8. Use normal methods for installing fittings, balusters, and newels. It is best to install and finish railing immediately.

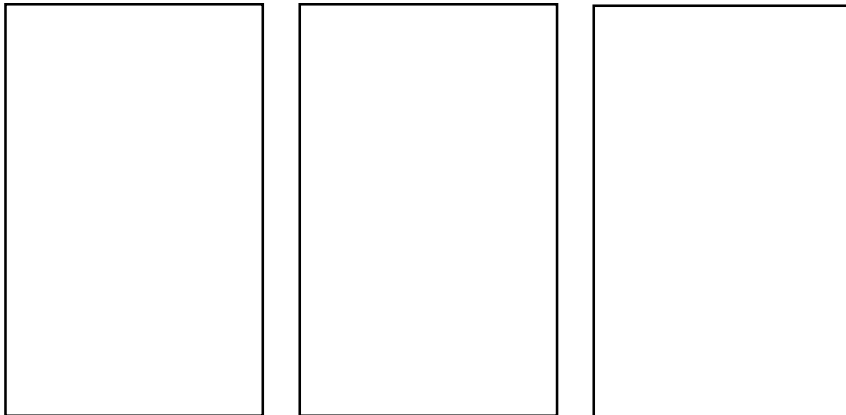

## 107-E MAKING A PITCHBLOCK

A pitchblock is a triangular piece of wood used to mark fitting easements for trimming at the proper angle. It may be made in one of two ways:

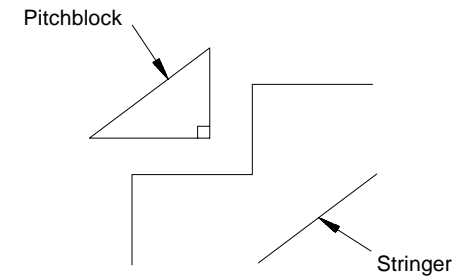

### ALTERNATIVE #1

**Alternative #1** - Use the triangular piece of off-fall from the stringer or . . .

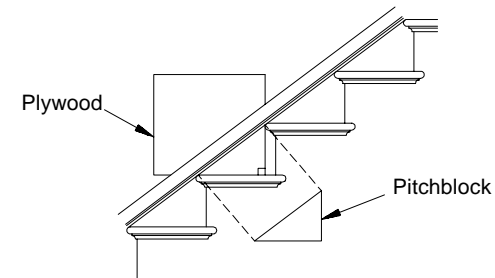

### ALTERNATIVE #2

**Alternative #2** - Use a piece of plywood. Clamp a piece of handrail to the nosing of the treads. Set the plywood on one tread and against the nose of the next tread (check this corner of the plywood to see that it is square). Mark and trim along the underside of the handrail.

Mark "rise," "run," and "rake" on the appropriate legs of the triangle and on both sides of the pitchblock. If the rise or run is different on different flights of stairs, make a pitchblock for each flight.



## 107-F USING A RAIL BOLT

1. Make a template to mark the rail bolt center by cutting a 1/8" piece off of a piece of handrail. Drill a 1/16" hole through the template as shown. Mark one side "Rail" and the other side "Fitting." Align the template on the end of the handrail and the fitting, marking the hole location for the rail bolt on each.

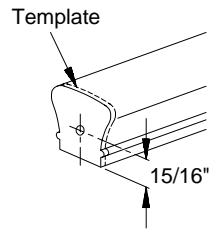

2. Drive two small finish nails into the handrail leaving 1/8" exposed. Trim the heads off. This will keep the assembled parts from rotating.

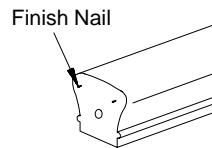

3. Drill all holes:

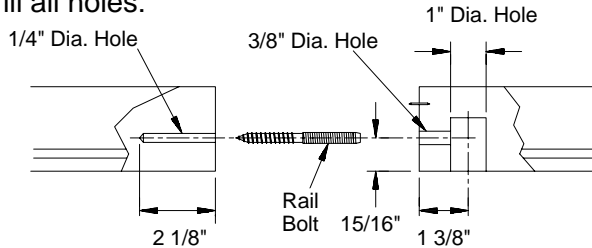

Drill all holes to the depth and diameter shown. Note: Use a forstner bit for the 1" hole.

4. Assemble:

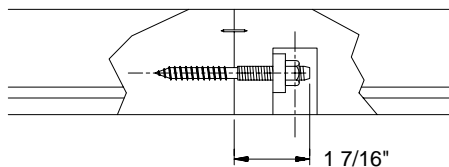

Double-nut the rail bolt to drive it into the fitting leaving 1 7/16" exposed. Temporarily assemble the parts using the washer, nut and a T-92 Rail Bolt Wrench. Use glue only on final assembly.

## 107-G STARTING STEP INSTALLATION

NOTE: More detailed instructions are included with each starting step.

### Install the Riser:

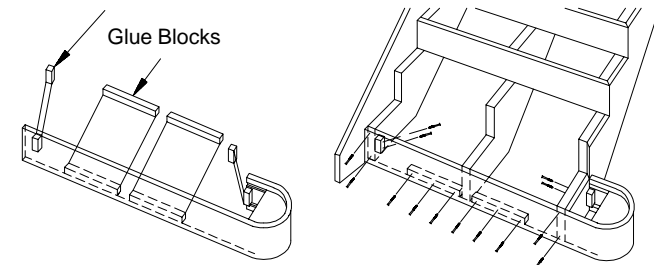

Trim the riser to size. Attach glue blocks to the floor and stringers as shown. Attach the riser to the glue blocks and stringers using screws and glue.

### Install the Tread:

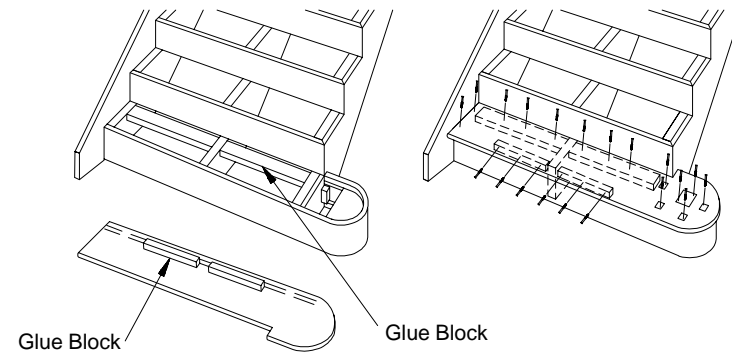

Trim the tread to length if necessary. Attach glue blocks to the tread and stringers as shown. Attach the tread to the glue blocks, stringers and riser using screws and glue.

### Install the Mouldings:

The curved and straight shoe and cove must be job trimmed to fit. Install with glue and finish nails.



## 107-H USING A 90 DEGREE STARTING FITTING

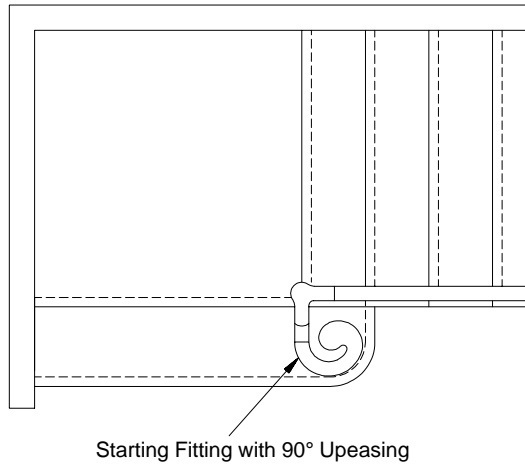

Use the template and layout instructions provided with the fitting to mark the centerpoints of the starting newel and landing newel and the starting step balusters.

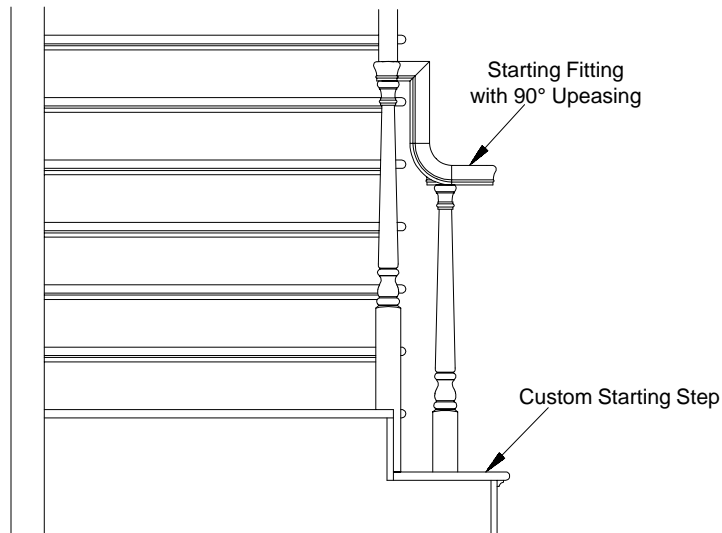

Note that a custom depth starting step (LJ-8440/8460 or LJ-8640/8660) is required due to the horizontal distance between the starting newel and the landing newel.

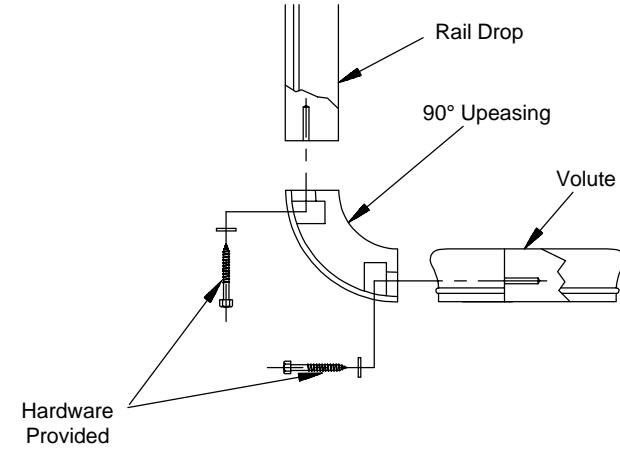

Trim the rail drop to length and drill a 9/32" x 1 1/2" deep pilot hole using the rail marking template provided. Use the hardware provided to assemble the starting fitting.

## 107-I USING AN OVEREASING

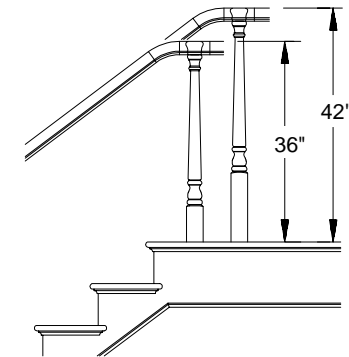

An overeasing is used to make the transition from the rake handrail to the level balcony handrail without the use of a vertical rail drop. It is marked and trimmed like the easing at the lower end of the flight, see steps 11 and 12. It is fastened to the handrails with rail bolts, see step 107-F. Note that the location of the overeasing has a direct effect on the balcony handrail height.



### 107-J USING A COPED END

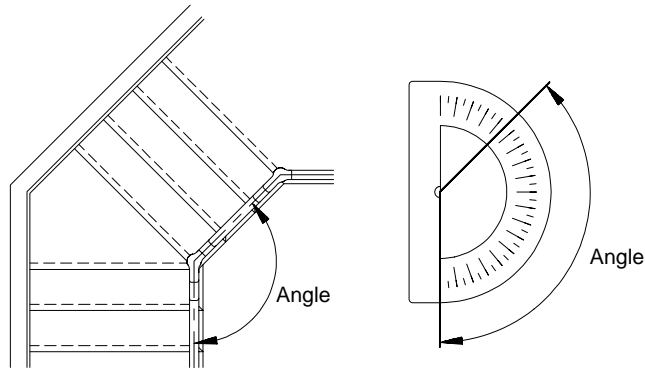

Angled fittings are used on stairways and balconies which have turns that are not 90 degrees. It is important to determine the angle created by the turn. This may be done with a protractor.

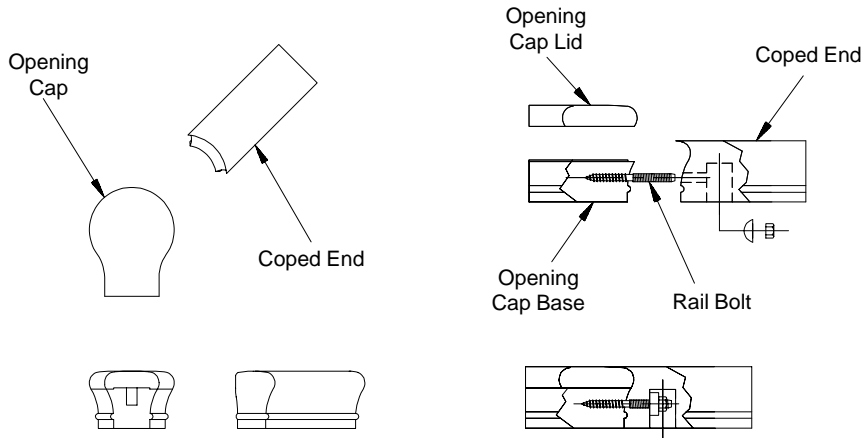

Quarterturns not measuring the standard 90 or 135 degrees may be assembled using an opening cap and a coped end. They are joined using a rail bolt as shown above. Step **107-F** details the use of rail bolts.

### 107-K WINDER TREADS

Increase the length of the rail drop by attaching an additional piece of handrail using rail bolts.

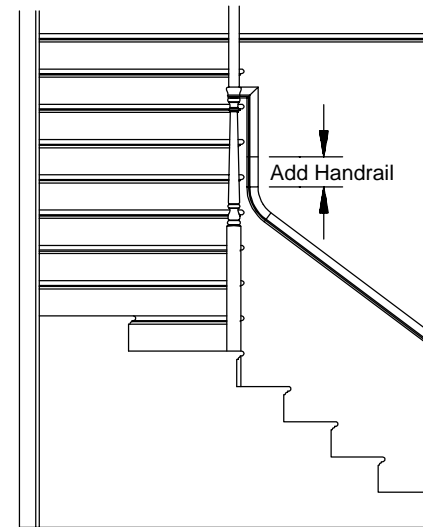
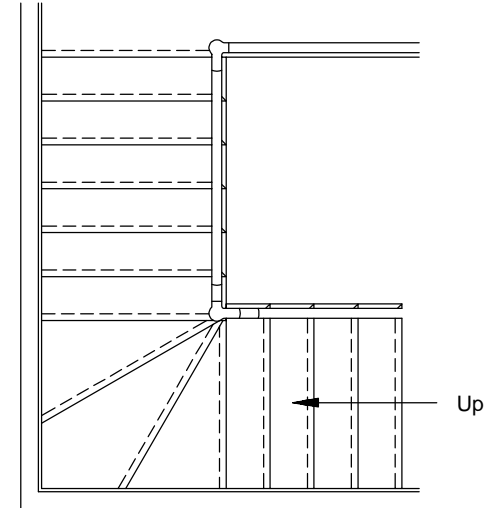

### 107-L ALTERNATIVES TO THE TELESCOPING BALUSTER MARKING TOOL

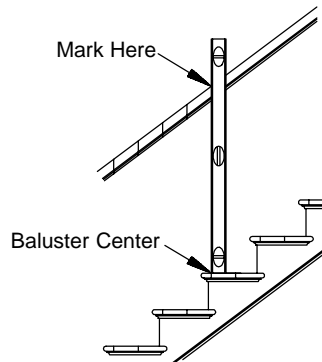

Use a framing square to transfer the baluster centerpoints from the treads to the side of the handrail. Remove the rail from the stair when completed.

### 107-M ALTERNATIVES TO THE DOWEL-FAST

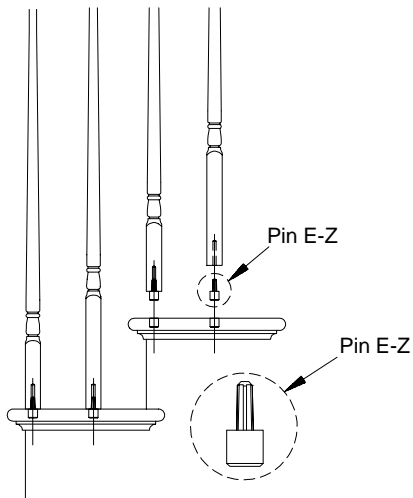

LJ line balusters are provided with a Pin E-Z, a wooden pin which is easily inserted into the 9/32" diameter hole in the baluster. The large end of the Pin E-Z fits into a 3/4" diameter hole drilled into the tread or balcony.

### 107-N ALTERNATIVES TO THE BOREBUSTER ALTERNATIVE 1

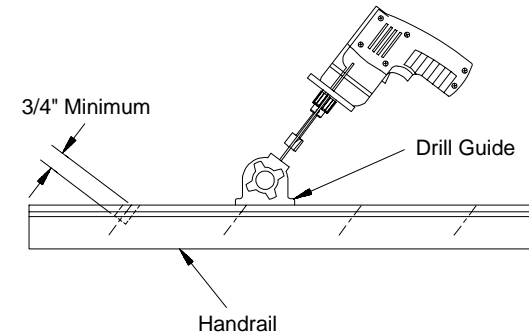

It is recommended that an angle-drill guide with a forstner bit be used to ensure the proper angle when drilling the handrail for baluster, as in Alternative 1.

### ALTERNATIVE 2

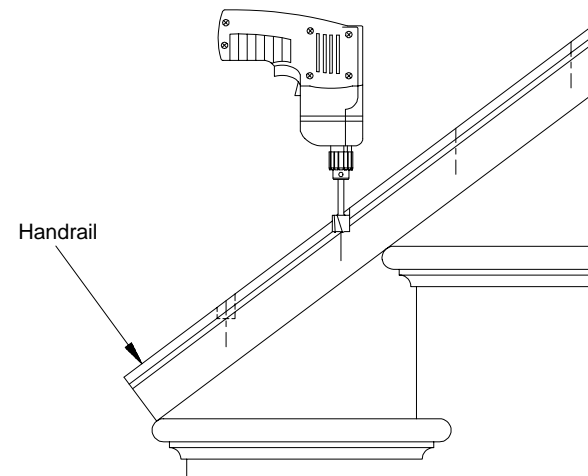

If a guide is not available, set the handrail upside down on the stair with the starting newel end of the handrail pointing up the stairs, as shown in Alternative 2.

The holes must be centered in the width of the handrail and should be a minimum of 3/4" deep at the center.



## 107-O BALUSTRADE CENTERLINE ON A HALF OPEN STAIR

The balustrade centerline on a half open stair may have to be shifted to allow for the use of a half-newel or rosette.

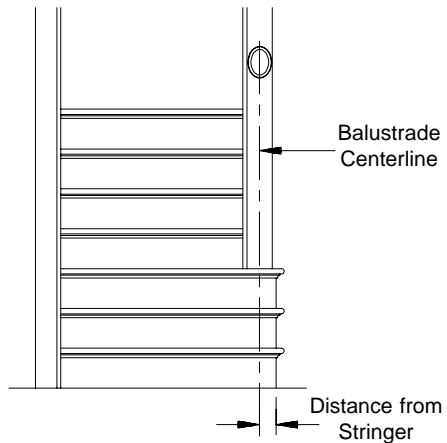

**Note:** Moving the balustrade centerline may affect the location of a starting fitting on a starting step in an over the post system.

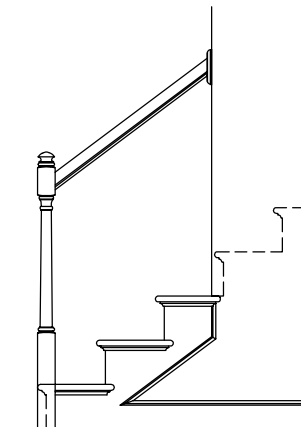

## 107-P USING A CLIMBING VOLUTE

All climbing volutes come with detailed installation instructions.

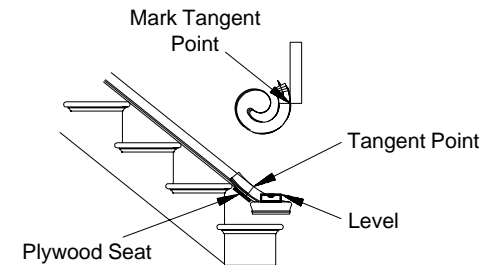

Tack nail a 6" x 6" piece of plywood to the underside of the rake handrail. Place a torpedo level on the volute and set the fitting on the plywood seat, adjusting the volute until the easing is tangent to the handrail. Mark the cut line at the tangent point. Make a preliminary cut just behind the cut line to test the angle of cut, then make the finished cut.

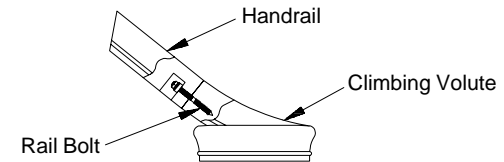

Assemble the volute to the handrail using a rail bolt. See Step **107-F** for details.

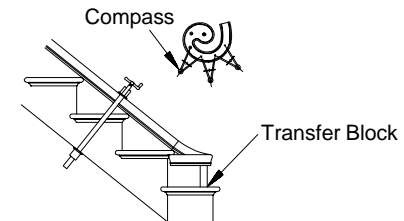

Use a compass to mark the baluster centerpoints on the bottom of the volute. Situate the handrail and volute on the stair with the volute centered over the starting step. Use a block of wood to transfer these marks to the tread.

CAUTION: It must be kept in mind, when using this index, that this Installation Guide is set up in a step-by-step manner. Taking an item out of sequence, such as balusters, does not allow for the various steps already completed prior to that item.

<b>GENERAL</b>	<b>SEE STEP</b>
APPENDIX .....	107
BALCONY PARTS .....	104
BALUSTER CENTERPOINTS .....	8,9
BALUSTER - DRILL BALUSTER HOLES IN HANDRAIL .....	87
DRILL BALUSTER HOLES IN TREADS .....	82
FASTENING BALUSTERS .....	88,89
TRIMMING BALUSTERS TO LENGTH .....	83,86
BALUSTRADE CENTERLINE .....	7
BENDING RAIL .....	107-D
BUILDING CODES .....	3
FALSE TREADS .....	107-C
FILLET .....	90,91
FINISHING .....	106
HALF NEWELS .....	92,95
HANDRAIL HEIGHT .....	3
NEWEL NOTCHING .....	107-A
PITCHBLOCK .....	107-E
RAIL BOLTS .....	107-F
ROSETTES .....	98

**OVER THE POST**

BALCONY FITTINGS .....	33
BALCONY NEWELS .....	45
CLIMBING VOLUTE .....	107-P
COPEDED ENDS .....	107-J
INTERMEDIATE LANDING FITTINGS .....	20
INTERMEDIATE LANDING NEWELS .....	43
NINETY DEGREE UP EASINGS .....	107-H
OVEREASINGS .....	107-I
STARTING FITTINGS .....	10
STARTING NEWELS .....	41
STARTING STEP .....	107-G

**POST TO POST**

BALCONY FITTINGS .....	71
BALCONY NEWELS .....	59
HANDRAIL - CUTTING TO LENGTH .....	79
FASTENING TO NEWELS .....	80
INTERMEDIATE LANDING FITTINGS .....	63
INTERMEDIATE LANDING NEWELS .....	56
SHOERAIL .....	61
STARTING NEWELS .....	53

Hand Drill with bits: 1/8", 1/4", 9/32", 3/8", 5/8", 3/4", 1"  
Hammer with 1" finish nails  
Putty Stick - to match color of stain  
Miter Box Saw  
Ratchet Wrench (use soap to lubricate lag bolts)  
2 Levels: torpedo & 4' level  
Tape Measure  
Wood Chisel  
Sandpaper: 100, 150, 220 grit  
Wood File  
\*Finishing Stain  
\*Polyurethane Finish  
Paint Thinner  
Steel Wool: "0000" fine grade  
Paint Brush  
Rags  
Tack Cloth  
Circular Saw  
Handsaw and/or Reciprocating Saw  
Vise Grips  
Carpenters Glue  
Construction Adhesive  
Bar Clamps  
Plumb Bob

**See L.J. Smith's Systems  
Catalog for their full line  
of "Stairway Installation  
Tools and Hardware."**

\*Refer to instructions on label for proper finishing instructions.

Form No. LJ-0694INST

Copyright 1994 L.J. Smith

\$1.50

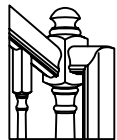

**L.J. Smith**  
**Stair Systems**

35280 Scio-Bowerston Road

Bowerston, Ohio 44695

Phone (614) 269-2221

FAX (614) 269-9047

DISTRIBUTED BY: